

TECHNICAL MANUAL
OPERATOR'S AND UNIT MAINTENANCE MANUAL
FOR
FIRING DEVICE, DEMOLITION. M122
(NSN 1375-01-021-0606) (EIC: 2NA)

DISTRIBUTION STATEMENT A: Approved for public release; distribution is unlimited.

HEADQUARTERS, DEPARTMENTS OF THE ARMY AND THE AIR FORCE

JULY 1994

WARNINGS

FAILURE TO OBSERVE WARNINGS CAN RESULT IN INJURY OR DEATH OF PERSONNEL.

DO NOT CHECK OUT DEMOLITION FIRING DEVICES M122 IN SAME AREA OR AT SAME TIME THAT OPERATIONS ARE BEING CONDUCTED WITH OTHER DEMOLITION FIRING DEVICES M122.

DO NOT CONNECT THE FIRING CIRCUIT UNLESS RECEIVER'S ARMING SWITCH IS IN "SAFE" POSITION.

DO NOT USE THE TRANSMITTER WITHIN 100 FEET OF ANY ELECTRIC BLASTING CAPS. KEEP THE TRANSMITTER'S ANTENNA COLLAPSED WITHIN UNIT AND ANTENNA CAP SCREWED INTO TOP OF CARRYING HANDLE UNTIL ACTUAL FIRING OF EXPLOSIVE CHARGE.

NEVER OPERATE THE M122 TRANSMITTER WITHIN 100 FEET OF ANY BLASTING CAPS OR OTHER ELECTRO-EXPLOSIVE DEVICES. DO NOT OPERATE OR CHECK OUT TRANSMITTER WHEN TRAVELING WITH A BOX OF BLASTING CAPS IN THE SAME TRUCK.

DO NOT CONNECT BLASTING CAP CIRCUIT TO A RECEIVER WHICH DOES NOT HAVE CONTINUITY BETWEEN BLASTING CAP BINDING POSTS. IT COULD ACTIVATE CAPS WHEN THE CONNECTION IS MADE.

AVOID CONTACT WITH TRANSMITTER ANTENNA WHEN PRESSING FIRE BUTTON. A SLIGHT BURN CAN RESULT FROM TOUCHING THE ANTENNA WHEN A SIGNAL IS BEING TRANSMITTED, IN ADDITION THE TRANSMISSION RANGE WILL BE REDUCED.

KEEP BLASTING CAPS AWAY FROM EXPLOSIVE CHARGES AND FACE AWAY FROM THE BLASTING CAPS WHEN PERFORMING OPERATIONAL CHECK OF THE RECEIVER.

LIST OF EFFECTIVE PAGES

TOTAL NUMBER OF PAGES IN THIS PUBLICATION IS 61
CONSISTING OF THE FOLLOWING:

<i>Page No.</i>	<i>*Change No.</i>
Cover	0
Inside Cover	0
A and B	0
i thru iv	0
1-1 thru 1-12	0
2-1 thru 2-12	0
3-1 thru 3-12	0
4-1 thru 4-2	0
A-1 thru A-2	0
B-1 thru B-4	0
C-1 thru C-6	0
D-1 thru D-2	0
Authentication Page	0

* Zero indicates an original page.

TM 9-1375-213-12-3
TO 11A20-16-1

THIS PAGE INTENTIONALLY LEFT BLANK

TECHNICAL MANUAL)
No. 9-1375-213-12-3)
TECHNICAL ORDER)
No. 11A20-15-1)

HEADQUARTERS
DEPARTMENT OF THE ARMY
AND THE AIR FORCE
Washington, D.C., 5 July 1994

**TECHNICAL MANUAL
OPERATOR'S AND UNIT MAINTENANCE MANUAL
for
FIRING DEVICE, DEMOLITION: M122
(NSN 1375-01-021-0606)**

REPORTING OF ERRORS

You can help improve this manual. If you find any mistakes or know of a way to improve the procedures, please let us know. Mail your DA Form 2028 (Recommended Changes to Publications and Blank Forms) or DA Form 2028-2, located in the back of this manual, direct to Commander, U.S. Army Armament Research, Development and Engineering Center, ATTN: SMCAR-LSB, Picatinny Arsenal, NJ 07806-5000. A reply will be furnished to you.

	Page
CHAPTER 1. INTRODUCTION	
Section I. General	
1-1 Scope	1-1
1-2 Forms, records, and reports	1-1
Section II. Precautions, Care, and Handling	
1-3 Precautions	1-2
1-4 Care and handling	1-2
1-5 Safety	1-2
Section 111. Description and Data	
1-6 General	1-2
1-7 Identification	1-3
1-8 Description	1-3
1-9 Functioning	1-10
1-10 Packing and packaging	1-10
1-11 Tabulated data	1-10
CHAPTER 2. OPERATING INSTRUCTIONS	
2-1 General	2-1
2-2 Precautions	2-1
2-3 Operation under usual conditions-preparation for use	2-2
2-4 Firing procedures	2-6
2-5 Cause of malfunctions	2-10
2-6 Disposition of defective unit	2-10
2-7 Application note	2-10
2-8 Operation under unusual conditions	2-10

*This manual supersedes TM 9-1375-213-12-3&P/TO 11A20-15-1, 25 November 1981, including all changes.

CHAPTER 3.	MAINTENANCE	<u>Page</u>
Section I.	Service Upon Receipt of Material	
	3-1 Precautions	3-1
	3-2 Unpacking and inspection by operator	3-1
Section II.	Operator Maintenance	
	3-3 Cleaning	3-1
	3-4 Cleaning batteries and contacts	3-2
	3-5 When to replace batteries	3-2
	3-6 Battery installation and replacement	3-3
	3-7 Disposal of used batteries	3-6
	3-8 Transmitter antenna replacement	3-6
	3-9 Checkout prior to use	3-7
	3-10 Carrying case repair	3-11
	3-11 Operator quarterly checkout/PMCS	3-11
Section III.	Organizational Maintenance	
	3-12 Battery/Battery pack testing,	3-11
CHAPTER 4.	SHIPPING AND STORAGE	
	4-1 Shipment	4-1
	4-2 Storage	4-2
	4-3 Shipping and storage data	4-2
APPENDIX A.	REFERENCES	A-1
APPENDIX B.	PACKING MATERIALS, ACCESSORIES, AND TOOLS.....	B-1
APPENDIX C.	MAINTENANCE ALLOCATION CHART	C-1
APPENDIX D.	EXPENDABLE AND DURABLE ITEMS LIST.....	D-1

LIST OF ILLUSTRATIONS

<i>Figure</i>	<i>Title</i>	<i>Page</i>
1-1	Transmitter and receiver of demolition firing device M122.	1-3
1-2	Transmitter of demolition firing device M122.	1-4
1-3	Receiver of demolition firing device M122 (top view)	1-4
1-4	Receiver of demolition firing device M122 (rear view).....	1-5
1-5	Carrying case, closed	1-5
1-6	Carrying case, open with contents	1-6
1-7	Transmitter of demolition firing device M122 (ready for use)	1-7
1-8	Battery pack	1-9
2-1	Example of target sheet.	2-5
2-2	Extending transmitter antenna	2-7
2-3	Holding transmitter (three position) in vertical attitude for firing ,	2-8
2-4	General layout of detonating cord firing system	2-11
3-1	Cleaning transmitter battery pack connector in battery compartment	3-3
3-2	Removing tight battery cap using the second receiver as wrench	3-4
3-3	Cleaning receiver battery contacts	3-5
3-4	Installing receiver battery.....	3-5

3-5	Improvising replacement antenna.....	3-8
4-1	Operating air valve.....	4-2
B-1	Control, remote, firing	B-2

LIST OF TABLES

<i>Table</i>	<i>Title</i>	<i>Page</i>
2-1	Number of Blasting Caps that Maybe Fired by One Receiver vs Firing Lead Length.....	2-1
2-2	Demolition Explosives and Accessories	2-2
3-1	Battery Test Parameters with battery at room temperature (between + 60° and+80°F) under load	3-12

TM 9-1375-213-12-3
TO 11A20-15-1

THIS PAGE INTENTIONALLY LEFT BLANK

CHAPTER 1

INTRODUCTION

Section 1. GENERAL

1-1. SCOPE

This publication, prepared for use by test personnel and interested Army elements, provides operator and maintenance instructions covering demolition firing device M122. The firing device M122 is used to detonate explosives from a remote location. The demolition firing device M122 consists of a separate transmitter and receiver. The transmitter transmits a coded radio signal to activate a specific receiver. The receiver, placed in the vicinity of the explosive, initiates the explosive upon receipt of the properly coded radio signal.

1-2. FORMS, RECORDS, AND REPORTS

a. General. Commanding Officers of units receiving demolition firing devices are responsible for preparation of records and reports. For reporting purposes, demolition firing devices are identified by serial numbers and standard nomenclature as described on its name plate.

b. Field Report of Accidents. Accidents involving injury to personnel or damage to materiel will be reported on DA Form 285 (Accident Report), in accordance with instructions in AR 385-40.

c. Malfunction Reports.

(1) Malfunction of firing device M122. A malfunction is a failure of a demolition firing device M122 to function in accordance with its intended purpose. During initial deployment, it is requested that defective components be

returned to the developing agency. Forward the items to Commander, US Army Armament, Munitions and Chemical Command, ATTN: AMSMC-MAE-T, Rock Island, IL 61299-6000. Remove batteries from the receiver and transmitter before packing. The units should be well-cushioned by crumpled newspapers, polyurethane foam, or whatever materials can be obtained.

(2) Reporting of malfunctions. For reporting purposes, malfunctions do not include accidents and fires resulting from negligence, malpractice and the like. However, malfunctions do include abnormal or premature functions if they occur in the course of normal handling, maintenance, storage, transportation and tactical deployment.

(3) Malfunctions involving ammunition or explosives. Malfunction reports involving ammunition must be forwarded to the Commander, US Army Armament, Munitions and Chemical Command, ATTN: AMSMC-QA, Rock Island, IL 61299-6000. A preliminary report will be made by the most expeditious means (e.g. by telephone Autovon 793-4851/Commercial 309-794-4851). Explosive ammunition malfunctions will be reported in accordance with AR 75-1. Ammunition malfunctions involving nonexplosive components that are not safety hazards will be reported in accordance with DA Pam 738-750.

d. Report of Damaged or Improper Shipment. Damaged or improper shipments will be reported immediately on Standard Form 364 (Report of Discrepancy ROD), (AR 735-11-2) and/or SF 361 (Discrepancy in Shipment Report) (AR 55-38).

Section II. PRECAUTIONS, CARE, AND HANDLING

1-3. PRECAUTIONS

WARNING

FAILURE TO OBSERVE WARNINGS CAN RESULT IN INJURY OR DEATH OF PERSONNEL. SINCE THE CONTROL UNIT OF THE M122 FIRING DEVICE IS A RADIO TRANSMITTER, IT SHOULD NEVER BE OPERATED WITHIN 100 FEET OF ANY PACKAGED OR UNPACKAGED ELECTRIC BLASTING CAPS OR OTHER EXPLOSIVE ITEMS CONTAINING ELECTRICAL INITIATORS.

1-4. CARE AND HANDLING

The following care and handling procedures will be observed to protect the M122 firing device.

a. Care.

(1) The device is designed to withstand conditions ordinarily encountered in the field.

However, care must be exercised to keep it from becoming broken or damaged.

(2) The device should be protected from mud, sand, moisture, frost, snow, ice, dirt, oil, grease, or other foreign matter. Wet or dirty devices should be wiped off immediately.

(3) Protect the M122 firing devices and batteries from sources of high temperatures (e.g., the direct rays of the sun).

b. Handling. Treat the M122 components with the same care in handling as you would any other electronic devices. Avoid dropping or otherwise impacting the devices. Pad and secure the devices during transport. These components ARE RUGGEDIZED but the less they are abused the better their reliability.

1-5. SAFETY

The M122 contains no explosives, however, the control unit (i.e., radio transmitter) can initiate electro-explosive initiators by means of its radiated radio frequent energy. Precautions outlined in FM 5-250, TM 9-1375-213-12, and this publication should be observed when in the vicinity of electro-explosive initiators such as blasting caps. Operators should be careful to avoid touching the control device antenna when transmitting because minor radio frequency burns MAY occur.

Section III. DESCRIPTION AND DATA

1-6. GENERAL

a. The Demolition firing device M122 (fig. 1-1) is designed to remotely initiate explosives by

means of a coded radio signal radiated by its transmitter to the receiver located at or near the explosives.

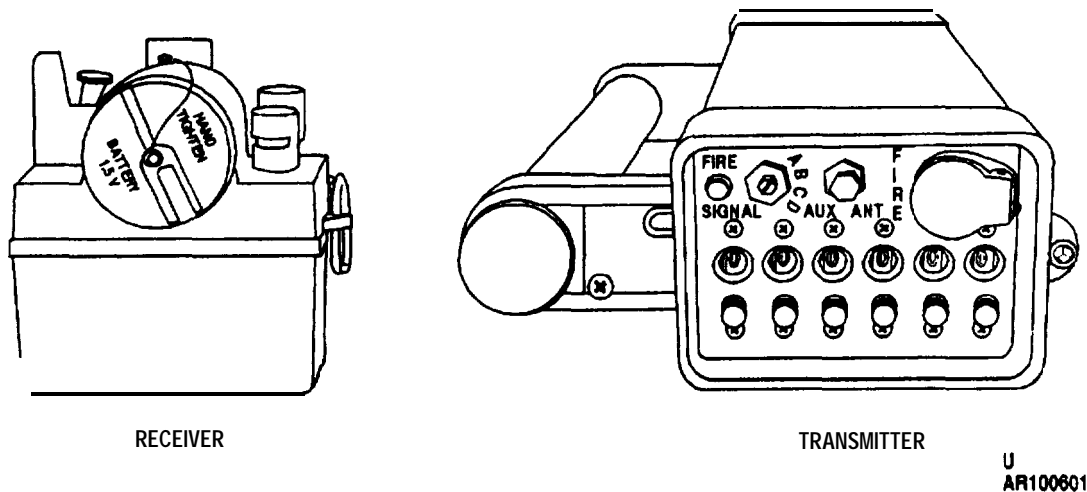

Figure 1-1. Transmitter and receiver of demolition firing device M122.

b. The maximum operating distance from the transmitter to receiver will vary with the terrain. The nominal operating distance is a minimum of 1000 meters (0.6 of a mile). Under adverse terrain conditions such as dense forest or frozen tundra, an operating range of less than 0.6 mile (1000 meters) may be experienced. In clear areas and with good weather where a line of sight exists between the transmitter and receiver, operations are possible at distances up to 3.2 kilometers (2 miles) over land, 5 kilometers (3 miles) over water, and 10 kilometers (6 miles) from aircraft to an open (uncovered) firing site.

1-7. IDENTIFICATION

The transmitter and receiver are colored olive drab with white marking. Metal identification plates on the transmitter and receiver bear the following information:

Transmitter ----- M122 Transmitter
Part No. 9252773
Serial No.

Receiver ----- M122 Receiver
Part No. 9279048
Serial No.

1-8. DESCRIPTION

a. General. The major components of the transmitter receiver are shown in figures 1-1 through 1-7. The transmitter is used for encoding and transmitting a radio signal and has its own antenna collapsed within the carrying handle. The receiver with an attached antenna wire is used for receiving and decoding the incoming radio signal. This signal triggers electronic firing of attached blasting caps that initiate explosive charges. The firing device is issued in sets consisting of one transmitter and 10 receivers in a fitted carrying case (fig. 1-5 and 1-6). The initial batteries and special battery pack will not be supplied with the item. Batteries and battery packs must be requisitioned through normal channels. Receiver batteries should be available for over-the-counter issue in most areas. Batteries or battery packs are not shipped installed in the devices and must be installed before checkout test or use.

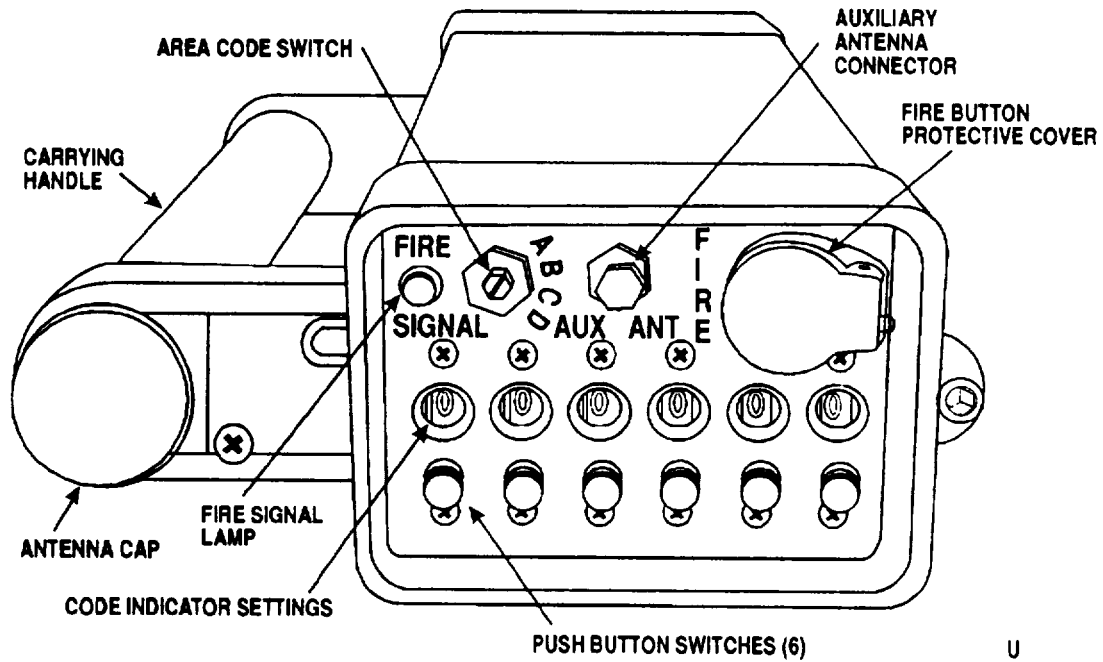

U
 AR100602-B

Figure 1-2. Transmitter of demolition firing device M122.

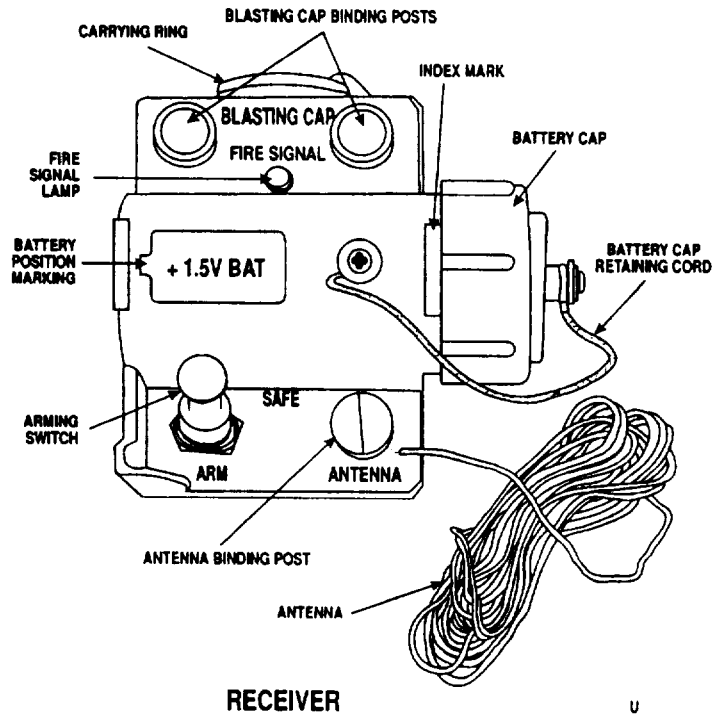

U
 AR 100605-B

Figure 1-3. Receiver of demolition firing device M122 (top view)

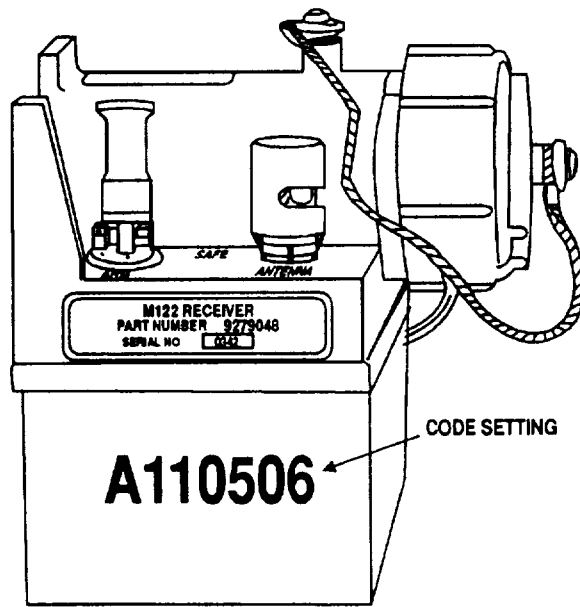

U
AR 100606-A

Figure 1-4. Receiver of demolition firing device M122 (rear view)

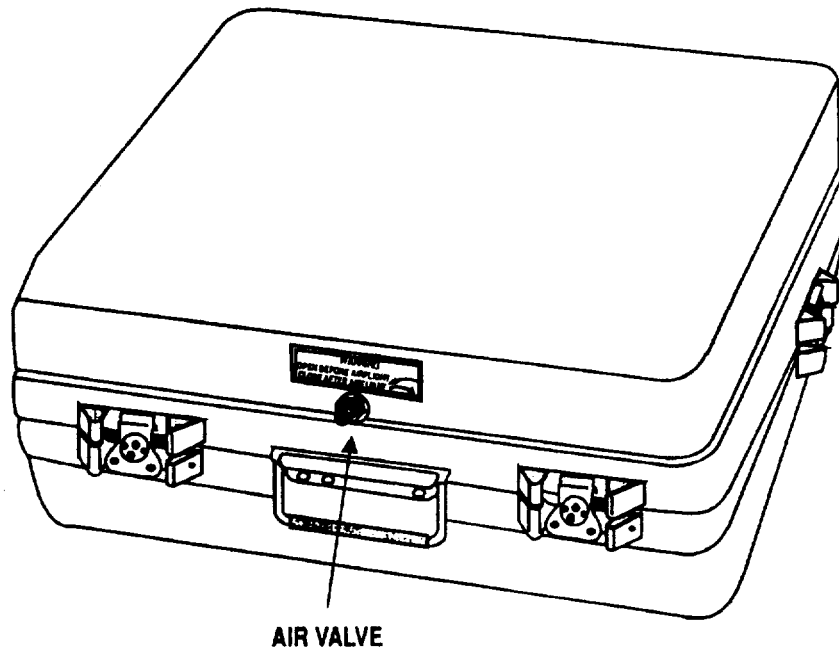

Figure 1-5. Carrying case, closed.

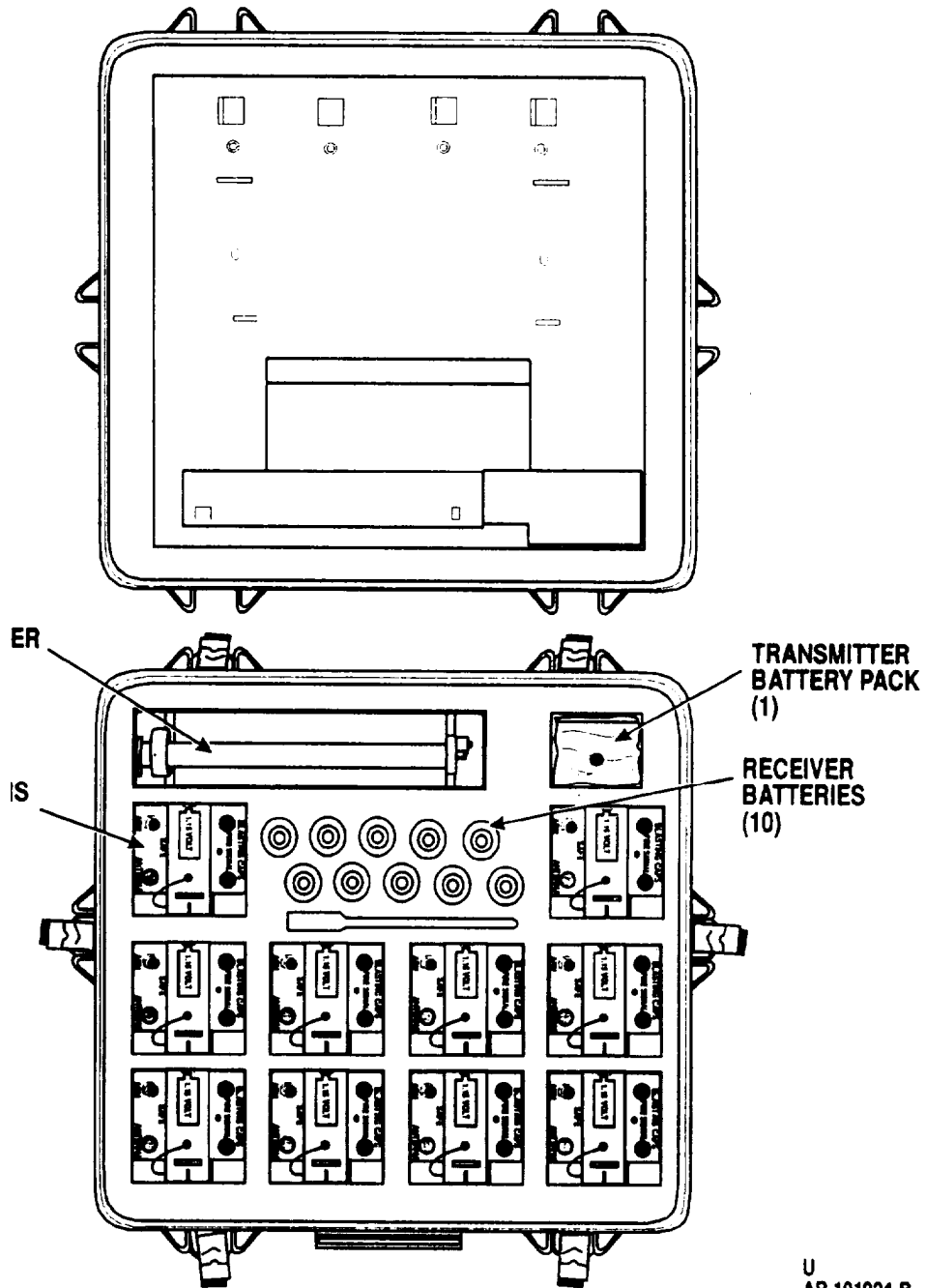
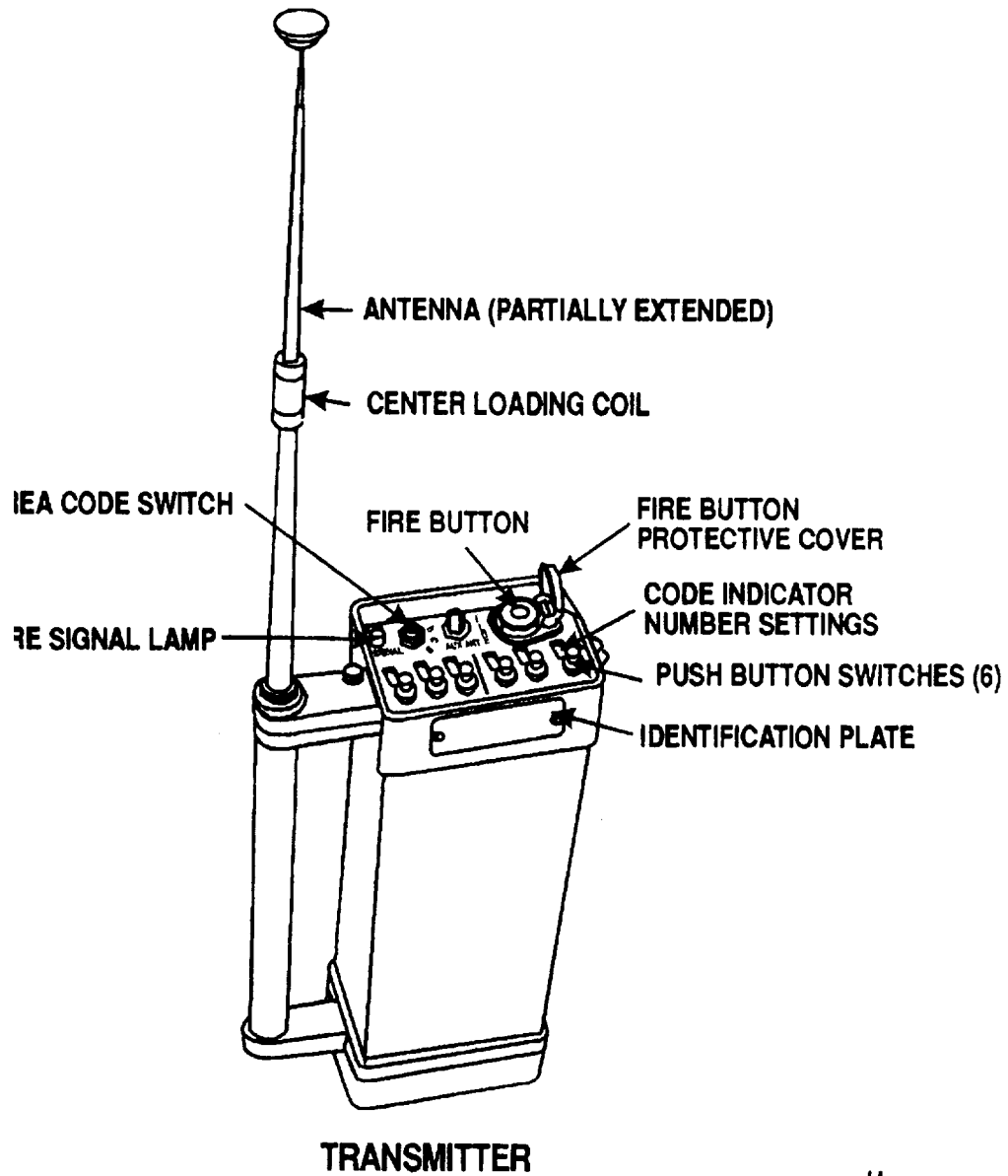

Figure 1-6. Carrying case, open with contents.



U
AR 100607-C

Figure 1-7. Transmitter of demolition firing device M122 (ready for use).

b. Transmitter.

(1) The transmitter (fig. 1-2 and 1-7) is a one piece, self-contained unit similar in appearance to a walkie-talkie. The fully transistorized unit which is powered by a battery pack can generate, encode, and transmit a radio signal to activate a receiver. Over a million different codes may be selected for transmission; therefore, many receivers may be activated from one transmitter in a short period of time.

(2) The following operational parts are accessible from the top of the transmitter (fig. 1-2).

(a) One four-position rotary area code switch used to select the letter of the code to be transmitted.

(b) Six push-button switches with visible numbers (0 to 7) to select the digits of the code to be transmitted or setting of the unit into a self-test mode.

(c) A fire signal lamp which indicates proper operation when the unit is being self-tested or used.

(d) A 47-inch telescopic antenna which can be totally collapsed within the transmitter carrying handle and then secured by a screw-on cap.

(e) A fire button with a spring-loaded protective cover.

NOTE

An identification plate bearing the item name, part number, and serial number is located on the side of the unit.

(f) A special antenna connector (female, MIL-C-39012/62-3002, radio frequency series SMA) is provided for factory use. It may be utilized by some users under special circumstances.

(3) Pushing the fire button (located beneath a spring-loaded cover on the top of the

unit) causes transmission of the selected signal. Power is provided by the special battery pack when installed in the unit.

c. Receiver. The receiver (fig. 1-3) is a small box with an integral, cylindrical battery compartment on top. It contains the electrical circuitry to fire the attached blasting caps upon receiving the properly encoded command signal from a transmitter. Special circuitry allows the receiver to be actuated only by receipt of a coded radio signal unique to the particular receiver. Each and every receiver has its own individual code. Power for the operation of the receiver and for the firing of the blasting caps is a single D cell. The receiver (figs. 1-3 and 1-4) incorporates the following features:

(1) An identification plate located on the side of the receiver.

(2) The code settings required for the receiver are stamped into the body adjacent to the identification plate.

(3) A carrying ring.

(4) A battery compartment with its screw-on cap. The screw-on cap incorporates a nylon retaining cord.

(5) A delay-arming switch.

(6) Antenna binding post.

(7) Two blasting cap binding posts.

(8) A fire signal lamp.

(9) An index mark (provided as visual reference to assure proper tightening of battery cap).

d. Batteries.

(1) The transmitter requires a special alkaline battery pack (fig. 1-8). A fresh battery pack should have the capacity to provide at least 1000 transmissions. Shelf life is about 18 months. Because it is a low usage item, it will not be stocked locally. It is advised that a fresh battery pack be requisitioned once a year whether the transmitter has had heavy usage or not. If the transmitter will receive heavy usage, order a replacement battery far enough in advance to allow for delivery from a central supply organization in time for use.

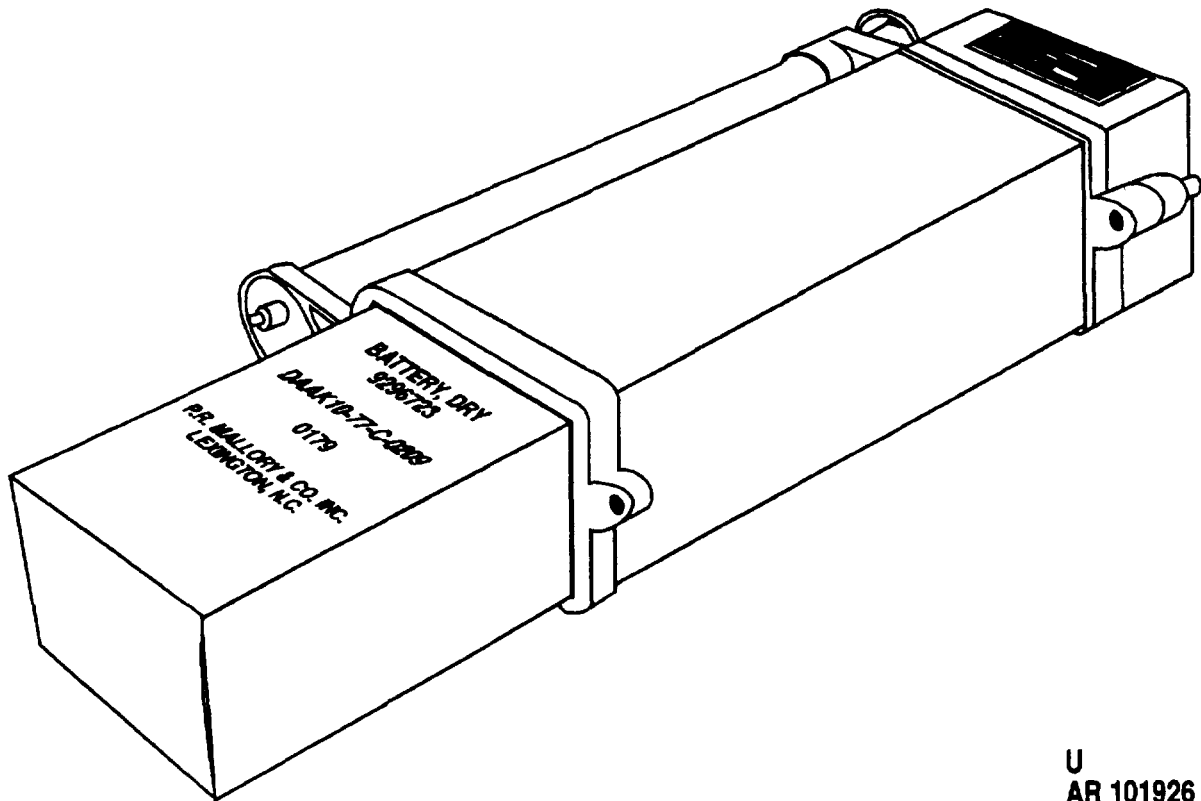

U
AR 101926

Figure 1-8. Battery pack.

(2) The receiver requires a fresh alkaline D cell for optimum operation. If an alkaline D cell is not available, a fresh standard zinc-carbon flashlight D cell may be substituted if the receiver will be used at a moderate temperature (approx +60 to +85°F). For extremely high operating temperatures (see tabulated data, para 1-11) a mercury D cell may be used. Mercury batteries generally have better high temperature characteristics than the alkaline types. Because of their physical differences (see note para 1-11), they may not work properly with some receivers. Therefore, whenever a mercury battery is used, always check out receiver (para 3-9) before use. Details on the batteries and their expected useful "on-duty" life are tabulated in paragraph 1-11.

e. Auxiliary Equipment.

NOTE

All auxiliary equipment necessary for setting up and operating the M122 is

available in Demolition Equipment Set, Explosive Initiating, Electric and Non-electric, NSN 1375-00-047-3750.

(1) Antenna wire for receiver. A 10-foot (3.3 meters) length of practically any insulated wire with half an inch of insulation stripped from one end for connection to the receiver will make a good antenna. The solid single conductor wire, NSN 6145-00-542-3968, available in the demolition equipment set will be satisfactory.

(2) Circuit test instruments. Either of the two standard blasting circuit test instruments may be used with the M122. The M51 test set, NSN 4925-00-999-3454, or the Blasting Galvanometers, NSN 6625-00-539-8444, may be used to check out the receiver itself as well as the blasting caps and firing circuit. Use of the M40 test set with an M57 firing device (as used with the M18A1, Claymore Mine) is not advised because it is rather cumbersome to adapt and hook up to plain wires.

(3) Blasting caps. In standard electrical initiation type operations, only M6 caps (NSN 1375-00-028-5224) should be used if more than one cap is required. If a standard cap is being used, it may be of any type that is compatible with the explosive charge or mine being initiated. See TM 9-1375-213-12 and FM 5-250 for more details.

(4) Firing lead wire. If a firing lead longer than the blasting cap lead wires is required, use of No. 18 AWG two-conductor electrical wire (lamp cord, NSN 6145-00-299-6172) is recommended. WD-1/TT field telephone wire may also be used. Use of ANY firing lead will limit the number of caps that can be fired by a receiver. This effect is detailed in chapter 2, Operating Instructions (table 2-1).

(5) Tools. A screwdriver, a pocket knife, and pliers available in the demolition equipment set are necessary to maintain and use the M122. The tapes in the set may also be necessary for some priming operations and for securing the receiver's antenna wire.

1-9. FUNCTIONING

When actuated by the transmitter, the receiver acts as a low capacity electric blasting machine. The full functioning sequence is as follows:

- a. Charges, mines, etc. are emplaced.
- b. The receiver is emplaced and its antenna is positioned vertically.
- c. Firing leads of the blasting caps circuit are connected to the receiver's blasting cap binding posts.
- d. Electrically prime the charge in the normal manner.
- e. The receiver's delay-arming switch is moved to the ARM position and the operating personnel withdraw to the remote firing location.
- f. After the arming delay period has passed, the transmitter, (set to the proper code) is functioned when desired and the receiver fires the blasting caps. The receiver can remain on duty awaiting its actuation signal for a long time (a nominal 20 days can be expected, depending upon environment and battery).

1-10. PACKING AND PACKAGING

The M122 is packed and issued as a set of 10 receivers and one transmitter in a fitted carry-

ing case (figs. 1-5 and 1-6). The carrying case is over packed in a wooden box for initial issue. The initial issue of batteries is packed inside the carrying case. Batteries in storage are plastic wrapped to prevent damage to components in case of leakage. Replacement transmitter battery packs come singly in cardboard boxes. Receiver batteries are bulk packed for over-the-counter issue.

1-11. TABULATED DATA

Packing Data:

Shipping box (with contents):

Length -----	25.5 in. (64.8 cm)
Width -----	24.5 in. (62.2 cm)
Height -----	11.5 in. (29.2 cm)
Weight (as shipped) -----	75.0 lb (34.0 kg)
Cube -----	4.2 cu ft (0.2 cu m)

Carrying case (w/contents, excluding batteries):

Size:

Length -----	23.75 in. (60.3 cm)
Width -----	22.75 in. (57.8 cm)
Height -----	8.8 in. (22.4 cm)
Weight -----	Approx 30 lb (13.6 kg)
cube -----	2.8 cu ft (0.08 cu m)

Transmitter:

Size (antenna collapsed):

Length -----	11.00 in. (28 cm)
Width -----	2.63 in. (6.37 cm)
Height -----	6.25 in. (15.87 cm)

Weight:

Without battery pack ---	2.25 lb (1 .25 kg)
With battery packed-----	4.25 lb (2 .13 kg)
Operating temperature -----	-25°F to + 125°F (-32W to +52°C)

Effective Range:

Nominal----- 0.6 mile (1 .0 km)

Estimated:

Through dense foliage ----- 0.6. mile (km)

Through dense jungle -- 0.5 mile (0.8 km) or

Over land (clear line-of-sight) ----- 2.0 miles (3.3 km)

Over water ----- 3.0 miles (5.0 km)

Over frozen tundra ----- 0.5 mile (0.8 km) or less

From aircraft (clear

line-of-sight) ----- 6.0 miles (10.0 km)

Receiver:
Size:
Length ----- 4 in. (10 cm)
Width ----- 4 in. (10 cm)
Height ----- 4 in. (10 cm)

Weight:
Without battery ----- 1.1 lb (0.5 kg)
With battery ----- 1.4 lb (0.6 kg)
Capacity Nominal (see table 2-1 for details) --- Five M6 Electric Blasting caps in series

Operating temperature w/alkaline battery ----- -25°F to + 125°F (-32°C to + 52°C)

Transmitter Battery Pack:
Type..... Alkaline
Voltage ----- 18 v
BA type.....N/A
NSN----- 6135-01-110-3516

Size:
Length ----- 5.1 in. (12.9 cm)
Width ----- 3.3 in. (8.4 cm)
Height ----- 2.3 in. (5.8 cm)
Weight ----- 2.0 lb (0.9 kg)

Marking (initial production only):
Battery, Dry----- 9296723
Contract No.
Date
18 volts
Manufacturer's name, Plant location

Receiver Battery:
----- Alkaline
Voltage----- 1.5 v

BA type..... BA 3030/u
NSN..... 6135-00-835-7210
Use ----- General and low temperature
Operating temp range ---- -25°F to + 125°F (-32°C to +52°C)

On-duty life Nominal ----- 20 days

Expected receiver on-duty life using fresh battery at various temperatures -- -25°F — 25 days;
+70°F — 50 days;
+ 125°F — 30 days

Type ----- Mercury*
Voltage ----- 1.35 v
BA type ----- BA 1030/u
NSN----- 6135-00-125-5265
Use ----- High temperature

Operating temperature range----- +70°F to +125°F (+21°C to +52°C)

Expected receiver on-duty life using fresh battery at various temperatures -- + 50°F — 1 day;
+ 70°F — 20 days;
+ 125°F — 30 days

“The BA 1030/u mercury battery does not have the protruding positive contact of alkaline and zinc carbon batteries. Because of this (a) always carefully check polarity of a mercury battery when installing, (b) rotate the mercury battery two full turns within battery compartment after inserting it, and (c) always assure the receiver's contacts are making proper contact by conducting a checkout of any receiver being used with a mercury battery.

TM 9-1375-213-12-3
TO 11A20-15-1

THIS PAGE INTENTIONALLY LEFT BLANK

CHAPTER 2 OPERATING INSTRUCTIONS

2-1. GENERAL

a. In field use, the receiver may be used as an expendable or nonexpendable item. When it is necessary or desirable to expend the receiver, it should be placed as close as possible to the explosive charge (on to of charge, if feasible). When the receiver is Not to be destroyed, a firing lead of sufficient length should be used. The nominal capacity of the receiver is five M6 caps wired in series. The actual number of caps that may be initiated by a receiver will depend u on the length and type of firing lead used. The lead lengths and allowable number of caps are tabulated in table 2-1 for each t e of wire. The blasting caps must be connected in series. Hookup of the firing lead and blasting caps should be in accordance with standard electric priming procedures. Refer to FM 5-250 and M 9-1375-213-12 for proper preparation of the explosive charges and priming. Since the receiver is essentially a low capacity blasting machine, standard electric priming techniques may be employed with it.

b. When the receiver is to be used frequently in a nonexpendable manner (on a demolition range, for example), locate receiver as far away as possible from explosive charge and protect the unit by digging a six inch deep hole in the ground. Place receiver in hole, leaving on] the antenna protruding above the ground.{f the antenna terminals will be covered with earth, protect them with tape or other water-proof material. The receiver ma be covered with sandbags or placed in a small wooden box or ammunition container. If an ammunition container is used, drill two 1/4-inch holes on the side of the container, one hole for the antenna wire and the other hole for blasting wires. The minimum distance that the receiver should be placed from the explosive will de end upon charge size, soil conditions, debris from explosion, charge setup, and fragments. For guidance purposes, the minimum safe distance for receiver placement from a 15 pound charge of TNT was found to be 15 feet (5.0 meters) in soft soil and buried below ground level.

Table 2-1. Number of Blasting Caps That May be Fired by One Receiver vs Firing Lead Length

Firing Lead Length* (ft)	No. of M6	No. 18 AWG** WD-1 Wire
	50 (or less)	15
100	14	9
200	13	8
500	12	2
1000	8	1

*Disregard length of M6 cap wires.

**M4 caps are M6 caps with an integral long firing lead. The lead of each M4 cap must be considered as 100 feet of No. 18 AWG firing lead.

c. If receiver is to be left on duty for an extended period before being used to fire the charge, the length of time a fresh battery will power the receiver in an on-duty state depends upon the type of battery and the temperature (see para 1-11). If the battery is not fresh, the on-duty time will be reduced. Criteria on battery freshness are given in paragraph 3-11 and table 3-1.

2-2. PRECAUTIONS

Operations using demolition tiring device M122 involve few precautions other than those required for normal explosive operations that use conventional electric priming. However, the misfire procedures are different from those for normal electric blasting operations. Care should be exercised in handling the units of the firing device. Both units are ruggedized and water resistant; but the less they are abused, the greater their reliability.

WARNING

- **IN OPERATION, THE TRANSMITTER RADIATES RADIO FREQUENCY SIGNALS AND, THEREFORE, SHOULD NEVER BE OPERATED WITHIN 100 FEET OF ANY ELECTRIC BLASTING CAPS OR ANY OTHER EXPLOSIVE ITEMS CONTAINING ELECTRICAL INITIATORS WHETHER THEY ARE PACKAGED OR NOT PACKAGED.**
- **AVOID CONTACT WITH ANTENNA WHEN PRESSING BURN CAN RESULT FROM**

TOUCHING THE ANTENNA WHEN A SIGNAL IS BEING TRANSMITTED ; IN ADDITION, THE TRANSMISSION RANGE WILL BE REDUCED.

**2-3. OPERATION UNDER USUAL CONDITIONS-
PREPARATION FOR USE**

a. Obtain the items listed below in table 2-2. All are available in Demolition Equipment Set, Explosive Initiating, Electric and Nonelectric: NSN 1375-00-047-3750. Check out operability of M51 test set and/or galvanometers in accordance with TM 9-1375-213-12.

Table 2-2. Demolition Explosives and Accessories

National Stock No.	Item
5110-00-162-2205	KNIFE, POCKET: Special Tools, can opener, punch blade, screwdriver and bottle opener w/clevis, one cutting blade, lg of blade 3-1/4 in. MIL-K-818 (81349)
5120-00-239-8251	PLIERS: Lineman's w/side cutter, 8 in. nom lg, GGG-P-471 TYPE 9 CLASS I STYLE A (81348).
	OR
5120-00-248-9420	PLIERS: Lineman's style, 8 in. nom lg, type 9, class 2, style A, GGG-P-00471 (81348).
4925-00-999-3454	TEST SET, BLASTING CAP: M51, 9227694 (19203)
	OR
6625-00-539-8444	GALVANOMETERS, BLASTING: w/case and carrying strap Spec WB-411 type 1
5970-00-644-3167	INSULATION TAPE, ELECTRICAL: Adhesive; cotton; coated ru impregnated per spec; 0.75 in. w, 82.5 ft to 85 ft lg, 0.015 in, thk, dielectric strength per spec; color coded black.
1375-00-028-5224 (M130)	CAP BLASTING: M6; sp, electric, 393653 (10001).
6145-00-542-3968	WIRE, ELECTRICAL: Solid conductor, round tinned copper; polyvinyl chloride, nylon jacket; No. 20 AWG, for use as receiver antenna.
	If a firing lead is to be used:
6145-00-299-6172	CABLE, POWER, ELECTRICAL: firing vinyl polymer ins. two condct No, 18 AWG stranded, 500 ft. coil, MIL-C-442.
	OR
6145-00-226-8806	CABLE, TELEPHONE: 2-conductor wire-500 foot reel, type WD -1/TT, Spec MIL-C-13294C.

b. Cut a 10-foot (3.3 meters) length of insulated, single conductor wire for a receiver antenna. Strip half an inch of insulation from one end of the wire. If the wire is enameled, use the dull edge of a knife blade to scrape the enamel off the wire.

NOTE

Any 10-foot (3.3 meters) length of insulated wire may be used as an antenna for the receiver. A two conductor (wire) lamp cord may be used, however use only one wire of this lamp cord for the antenna. Strip half an inch of insulation from one of the conductors (wires) for connection to the receiver. Make sure that the other conductor of the lamp cord is not touching the conductor that is attached to the receiver at ANY POINT.

c. Install batteries and conduct a checkout of all transmitters and receivers in accordance with paragraph 3-9. If the receiver is to be left on duty for an extended period of time refer to paragraph 3-11 and table 3-1 for expected on-duty times.

WARNING

NEVER OPERATE THE M122 TRANSMITTER WITHIN 100 FEET OF ANY BLASTING CAPS OR OTHER ELECTRO-EXPLOSIVE DEVICES. DO NOT OPERATE OR CHECK OUT THE TRANSMITTER WHEN TRAVELING WITH A BOX OF BLASTING CAPS IN THE SAME TRUCK.

d. Transport checked-out transmitter(s), receiver(s), and other required items to operational area. Provide M122 components with secure stowage during vehicle transport so they will not be bounced about or dropped during transport.

NOTE

If components are accidentally dropped, damaged or impacted in transit, they should be checked out again before use in accordance with paragraph c above.

e. If practical, choose a transmitter location that provides a clear line of sight to the receiver and within a kilometer of the receiver. Refer to paragraph 1-11 which gives expected maximum operational ranges for the M122 under different conditions. These are MAXIMUM operational ranges. It is always desirable to have the transmitter as close as practical to the receiver.

f. Refer to table 2-1 for the number of caps and firing lead lengths allowable and plan the details of the operation accordingly.

g. Emplace the explosive(s), mine(s), or other device(s) to be actuated by the receiver in accordance with FM 5-250 or other standard approved procedures.

h. Prior to use, check each blasting cap for continuity using blasting galvanometers or M51 test set in accordance with standard procedures in TM 9-1375-213-12 and FM 5-250. A flash of the test set's lam or a wide deflection of the galvanometer's needle indicates a complete circuit.

i. Wire the blasting caps in a series or parallel circuit in accordance with standard procedures. Use electrical tape to insulate each splice to prevent accidental shorting or grounding.

(See part III)

NOTE

Do not at this step of the procedure put caps into the explosives.

j. Check the blasting cap circuit with a blasting galvanometer or M51 test set. A flash of the test set's lam or a wide deflection of the galvanometer's needle indicates a complete circuit. Temporarily twist the ends of blasting cap leads together to short circuit them.

k. Use the following procedures if a firing lead is being employed:

(1) Lay out firing lead from the blasting caps to the receiver site. Strip an inch of insulation from each conductor of the firing lead at the receiver end; twist the bared conductors together to short circuit them.

(2) Strip an inch of insulation from each conductor of the firing lead at the blasting cap end. Check firing lead continuity from blasting site using galvanometers or M51 test set.

(3) After clearing all unnecessary personnel from the area, untwist the shorted blasting cap circuit leads and connect the blasting cap circuit leads with the firing leads in accordance with standard procedures. Insulate each splice with electrical tape. At receiver site untwist firing lead conductors and check continuity of full firing circuit using galvanometers or M51 test set. Twist firing leads together after test.

NOTE

Code switches should be set to zero until transmitter is to be functioned. The operator should have the transmitter in his possession at all times during the following steps:

1. Assure that receiver's arming switch is in **SAFE** position and the battery cap is securely tightened down.

m. Check out continuity between receiver's blasting cap binding posts.

(1) Strip an inch of insulation from both ends of two short lengths of wire.

(2) Secure one end of each wire into a blasting cap binding post of the receiver (site down post, insert wire into opened hole, release post to secure).

(3) Use a blasting galvanometers or M51 test set to assure continuity between the blasting cap binding posts.

(a) Connect or hold the short length wires from receiver to the instrument posts.

(b) Function test set M51 while watching its lamp or function galvanometers and observe needle.

(c) Lighting of the test set lamp or a wide deflection of the galvanometers needle indicates continuity exists and the receiver is (4) below. If continuity exists, proceed to step

(d) If instrument indicates there is no continuity between blasting cap binding posts, check connections and repeat test. If the instrument still indicates **NO** continuity **DO NOT USE THE RECEIVER**. Tag the bad receiver with a statement of the problem (e.g., **NO CONTINUITY — DO NOT USE**) and turn it in when practical along with a malfunction report (see para 1-2).

(e) Disconnect wires from test instrument posts.

(4) Remove the short length wires from the receiver's binding posts (push down post, pull out wire, release post).

NOTE

If the antenna wire cannot be suspended vertically lay it out on the ground in a straight line pointing towards or away from the expected transmitter location. The effective operational range will be significantly reduced with the receiver's antenna on the ground.

n. Place the properly checked-out receiver in the desired location. Secure stripped end of 10 feet of antenna wire in antenna binding post and tape antenna wire to a tree or other nearby object. Suspend the antenna as vertically as possible. Do not suspend antenna by tying the wire itself around a branch, this will reduce its effective length and therefore reduce its receiving ability.

o. Write down the code and location of each receiver. **ALWAYS** do this.

NOTE

When multiple receivers are used, it is recommended that a grid coordinate targeting sheet be used (fig. 2-1). This example contains all necessary information needed during the target turn-over to enable the operator to effectively and accurately denote explosives placed.

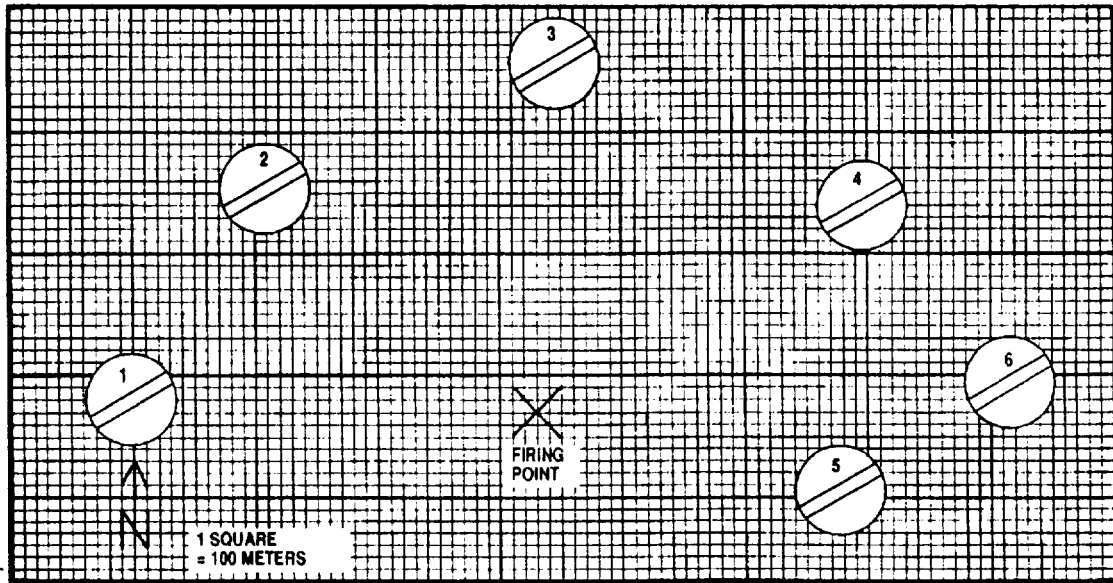

NO.	SERIAL NO.	CODE	TARGET DESCRIPTION	LOCATION	REMARKS
1	A12257715	020189	ROAD CRATER	NG 57718619	CHARGE UNDER DIRECTORY
2	B10124465	340126	TELEPHONE POLE	NG 56228513	
3	C12648176	124037	TELEPHONE BOOTH	NG 52287010	
4	C13394652	217869	TELEPHONE POLE	NG 34110925	
5	B11162115	138042	RAIL JUNCTION	NG 59117735	
6	C25760270	526783	SWITCH CONTROL BOX	NG 38257925	

U
AR2729

Figure 2-1. Example of Targeting Sheet

WARNING

DO NOT CONNECT BLASTING CAP CIRCUIT TO A RECEIVER WHICH DOES NOT HAVE CONTINUITY BETWEEN THE BLASTING CAP BINDING POSTS. IT COULD ACTIVATE THE CAPS WHEN THE CONNECTION IS MADE.

NOTE

Assure that the wire insulation is not in the binding posts. Such an improper connection will cause a misfire.

p. Clear the area of unnecessary personnel. Keep blasting caps away from the explosive charges.

WARNING

KEEP BLASTING CAPS AWAY FROM EXPLOSIVE CHARGES AND FACE AWAY FROM THE BLASTING CAP WHEN PERFORMING OPERATIONAL CHECK OF THE RECEIVER.

Untwist shorted firing lead conductors or blasting cap circuit conductors and secure one conductor in each of the receiver's blasting cap binding posts.

r. Hold receiver still with one hand, lift the arming switch lever, and move it to the ARM position. After 15 seconds lift and move the arming switch back to the SAFE position.

s. Secure caps to explosives in accordance with standard procedures.

t. When it is desired to start the receiver's arming cycle, hold the receiver still with one hand, lift the arming switch lever, and move it to the ARM position. Note the time of day.

u. Clear the area of all friendly personnel and proceed to the transmitting location. Whenever possible, the transmitter should be located so there is a clear line of sight from transmitter to receiver. The fewer obstructions between transmitter and receiver, the greater the possible range and the less chance of misfire. Maximum operating ranges for various conditions are given in paragraph 1-11.

NOTE

It takes the delay arming timer a minimum of four minutes to arm the receiver (i.e., to put it into a state wherein receipt of the properly encoded signal will actuate it and fire the connected blasting caps). The exact arming time will vary with conditions, etc., so always allow 8 minutes before attempting to fire the device.

2-4. FIRING PROCEDURES

WARNING

M122 IS CAPABLE OF INITIATING EXPLOSIVE TRAINS REGARDLESS OF POSITION OF ANTENNA. DO NOT DEPRESS FIRING BUTTON UNTIL READY TO FIRE.

NOTE

Before firing, allow 8 minutes to pass after the arming switch is set to ARM.

a. Unless the battery is exhausted or the receiver's arming switch is manually set to SAFE, the receiver will fire its connected blasting caps whenever it receives the programmed, coded signal. If the receiver is to be left on duty for an extended period, refer to paragraph 1-11 and table 3-1 for expected receiver on duty times under various operating conditions. Refer to paragraph 3-11 and table 3-1 on how to test for battery freshness.

(1) When it is desired to fire the receiver's caps:

(a) Set the receiver's code in the transmitter. Set letter using area code switch. Set numbers using the six push button switches,

CAUTION

WHEN USING ONE TRANSMITTER TO ACTIVATE TWO OR MORE RECEIVERS IN SUCCESSION, ALLOW APPROXIMATELY 3-4 SECONDS DELAY BETWEEN FIRINGS.

(b) Unscrew the transmitter antenna cap and extend the antenna to its full 47-inch length (fig. 2-2). To assure full extension of antenna, set transmitter on ground or hold between knees. Extend antenna by screw cap until coil appears. Hold coil with one hand and fully extend upper portion of antenna using other hand. Grasp coil and fully extend lower portion of antenna.

WARNING

AVOID CONTACT WITH ANTENNA WHEN PRESSING FIRE BUTTON. A SLIGHT BURN CAN RESULT FROM TOUCHING THE ANTENNA WHEN A SIGNAL IS BEING TRANSMITTED IN ADDITION TO THE TRANSMISSION RANGE BEING REDUCED.

(c) Hold the transmitter in a vertical attitude (see fig. 2-3 and (2) below), Lift FIRE button cover and push the FIRE button. Hold the FIRE button down for at least five seconds.

(2) Operator will obtain greater transmitting range when operating the transmitter by:

(a) Holding transmitter against chest.

(b) In kneeling position, place transmitter on knee.

(c) Placing transmitter on ground or on top of a large metal surface such as the top of a vehicle, etc.

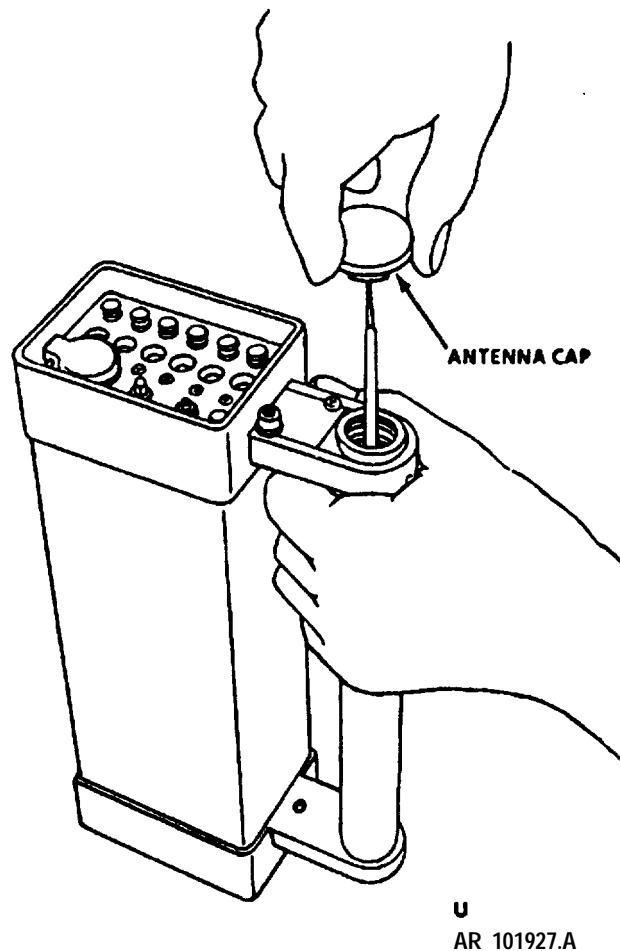
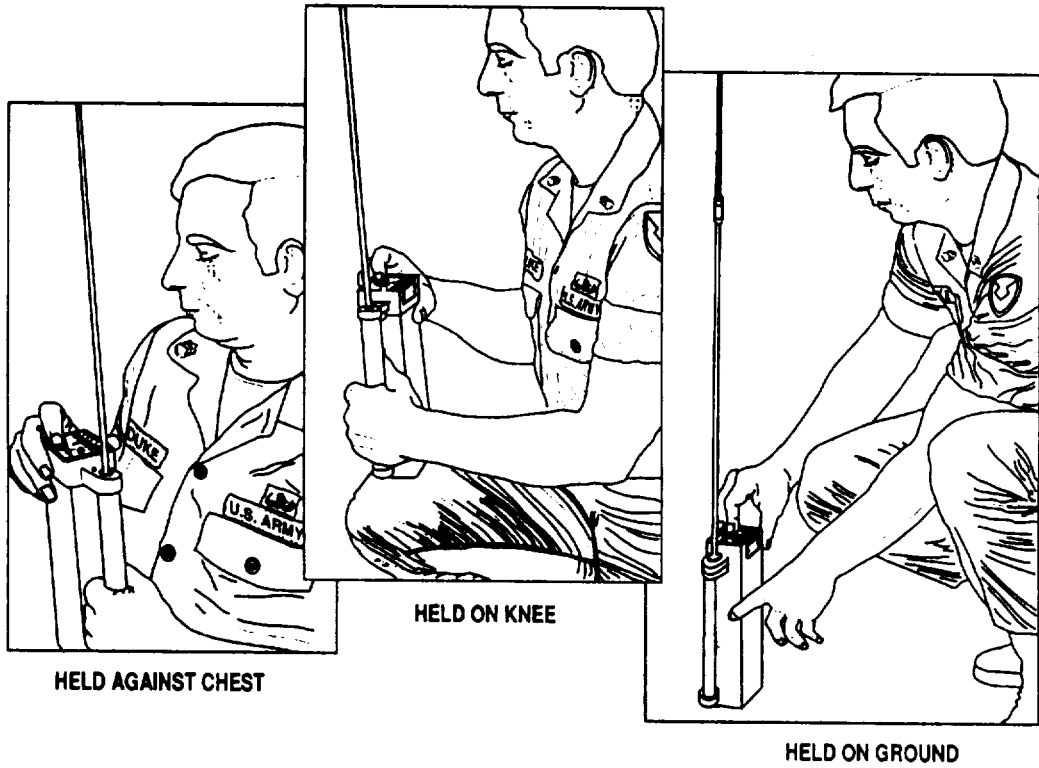

Figure 2-2. Extending transmitter antenna.



U
AR 101928-A

Figure 2-3. Holding transmitter (three positions) in vertical attitude for firing.

b. To recover the receiver for reuse, proceed as follows:

(1) Return to the receiver site only after it has been determined that the charge has fired. In event of misfire, refer to paragraph 2-4c below.

(2) Hold receiver body steady and lift arming switch and move it to the SAFE position.

(3) Disconnect the firing leads and antenna from receiver.

c. Misfire procedure if charge fails to fire when the FIRE button is pushed is as follows:

(1) Recheck to make sure at least 8 minutes have passed since the receiver's arming switch was moved to the ARM position.

(2) Recheck the transmitter's code setting. Use a flat tip screwdriver to rotate area code switch back and forth through all positions five times. Reset area code.

(3) If 8 minutes have definitely passed since arming the receiver, again lift the FIRE button cover and press the FIRE button.

(4) If the charge still fails to fire, set the code to all zeros, (any area code) lift the FIRE button cover, press and hold FIRE button for 5 seconds, and observe lamp. If the FIRE SIGNAL lam fails to light, secure another transmitter, if possible, an attempt to fire the charge with it.

(5) If FIRE SIGNAL lamp lights, reset transmitter for proper code settings for the specific receiver being used and move closer to receiver if such movement can be safely undertaken from both a tactical standpoint as well as consideration of the safe distance from the explosive. In addition to moving closer to receiver, relocate transmitter, if possible, so that its signal will reach the receiver from a different direction,

(6) From the new position, lift the FIRE button cover and push the FIRE button once again.

(7) If above procedure still fails to result in initiation of the explosives, if possible, secure another transmitter. Set the proper code and attempt to fire the charge in the normal manner.

(8) If another transmitter cannot be secured or if it too fails to initiate the charge, proceed as follows:

(a) Reset transmitter to zero at transmitter site.

WARNING

WAIT 1/2 HOUR BEFORE APPROACHING A MISFIRED CHARGE. WHEN A OPERATOR APPROACHES RECEIVER AFTER A MISFIRE, IT IS ADVISABLE THAT HE TAKE THE TRANSMITTER WITH HIM IN ORDER TO PREVENT THE RECEIVER FROM BEING INADVERTENTLY ACTIVATED BY SOMEONE ELSE. THE TRANSMITTER'S ANTENNA SHOULD BE RETRACTED.

NOTE

During waiting time check out another receiver, if available, refer to paragraph 3-9d.

(b) After waiting 1/2 hour, approach receiver and separated and cut lead wires from receiver blasting cap binding posts one at a time without disturbing receiver or caps and connections.

(c) Strip an inch of insulation from the cut lead wires and twist the wires to short them. Remove remaining sections of cut wires from binding posts.

(d) Place caps safely away from charges and personnel, Check cap circuit using M51 test set or galvanometers. Check wires for visual damage in the process.

(e) Using new receiver repeat hook-up sequence starting with paragraph 2-31.

(f) If a new receiver is not available, check out current receiver as follows:

1. Retrieve and hold receiver steady and lift and move arming switch to the SAFE position.

2. Assure that the receiver's battery cap is tightened to the index mark located on the receiver's battery compartment (fig. 1-3).

3. Assure receiver's antenna is properly connected and is NOT being grounded.

4. Assure firing circuit has been properly connected.

5. If the problem is one of those in (2), (3), or (4) above, correct as required and repeat arming and firing procedure beginning with paragraph 2-3m. If the problem is not one of those listed in (2), (3), or (4) above, use a standard blasting machine to complete the operation. Refer to 2-5 below and perform the required maintenance. Check out ALL components involved. Turn in and report defective items.

2-5. CAUSE OF MALFUNCTIONS

If during use or checkout a unit appears defective, the usual cause is weak or defective batteries. Corrosion of the battery contacts is a common cause of a malfunctioning unit. These defects should be corrected by the operating personnel. Procedures for battery replacement and cleaning of battery contacts are detailed in paragraph 3-6. If the unit after battery replacement and cleaning of battery contacts is still not restored to operating condition, the electronic components may be defective. Before this conclusion may be definitely drawn, the suspect unit should be checked out with another components unit (i.e., use another previously checked-out transmitter or receiver to check a transmitter or receiver.) Refer to paragraph 1-2 for reporting of malfunctions.

2-6. DISPOSITION OF DEFECTIVE UNITS

If during checkout or use, a unit is found to be defective and the cause is not weak batteries or corroded battery contacts the defective component should be turned in. During initial deployment return defective components to the developing agency. Forward the item to Commander, US Army Armament, Munitions and Chemical Command, ATTN: SMCRI-DLP (R), Building 299, Rock Island, IL 61299-5000. Remove battery pack from the receiver and transmitter before packing. The units should be well-cushioned with crumpled newspapers, polyurethane foam, or whatever cushioning materials can be obtained. Return of defective

units to development agency will permit evaluation of the units.

2-7. APPLICATION NOTE

For demolition projects requiring a larger number of caps than a receiver can fire, the receiver CAN be used with one or two electric blasting caps to initiate a detonating cord primed system (fig. 2-4). The detonating cord primed system is set up in the normal manner as described in TM 9-1375-213-12, FM 5-250 and other application type FMs.

NOTE

If a misfire is experienced in this type of application, it is advised to first cut the detonating cord to isolate the cap from the main demolition set up.

2-8. OPERATION UNDER UNUSUAL CONDITIONS

a. Cold. When the temperature is much below $\pm 50^{\circ}\text{F}$ an alkaline battery MUST be used in the receiver to get a reasonable on-duty time. If snow is present or anticipated, place a plastic bag or other available nonmetal covering around the receiver and tie the open end around the wires to keep snow or moisture from the binding posts where it could cause a short between wires or ground them. The transmitter battery pack is alkaline and will operate the transmitter right down to the lower operating temperature limit, however, because its capacity is diminished by the cold, it is advisable to keep it warm to gain maximum range. Therefore, if possible, in sub-freezing temperatures keep the transmitter under your outer-parka until it is time to use it. Operation of transmitter with operator wearing gloves requires that a pencil or small object be used to depress the FIRE button. ALWAYS protect the receiver from snow and rain using a plastic bag or by carrying it under your coat.

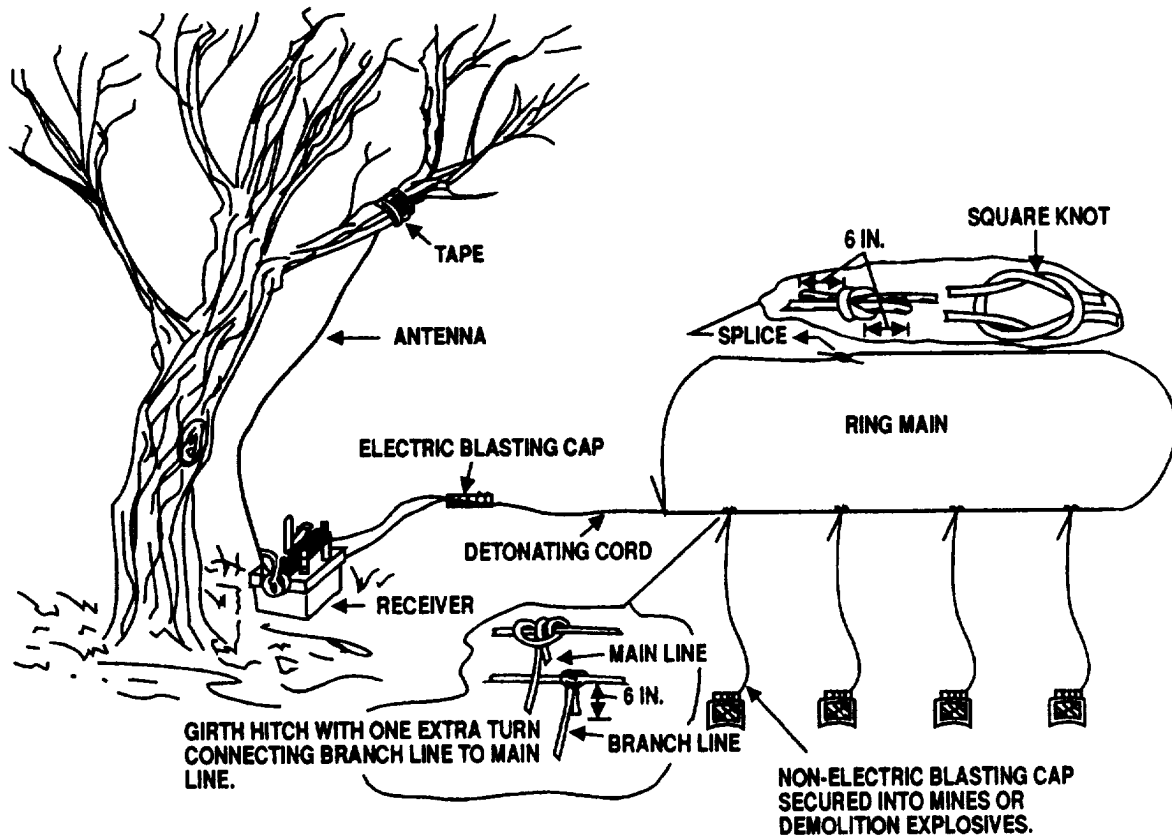

U
AR 100613

Figure 2-4. General layout of detonating cord firing system.

NOTE

Extra force is necessary to push the transmitter's fire button at extremely cold temperatures. If the rubber boot over the FIRE button has been cut, moisture can penetrate into the switch mechanism below and if it freezes, extremely high force may be necessary to push the FIRE button.

b. Moisture. As mentioned above, protect both receiver transmitter from moisture. Both components are moisture resistant and the internal parts are protected, but the external push buttons, switches, and binding posts are vulnerable so special care should be taken to protect them. Neither component will operate when submerged in water. If they do drop into water quickly retrieve them and dry them off immediately.

c. Heat and Sun.

(1) Batteries, When the daytime temperature goes above +9°F, use of the mercury battery in the receiver will generally give a longer on-duty time. Mercury batteries generally have better high temperature characteristics than the alkaline types. Because of their physical differences (see para 1-11), they may not work properly with some receivers. When using a mercury battery ALWAYS check out the receiver (para 3-9) before the mission (see Note, para 1-11). Though alkaline batteries operate well at elevated temperatures, they occasionally leak. The leaked material can quickly corrode the contacts which will break the electrical connection between battery and receiver and turn off the power (open circuit). When this happens, the battery may still be good but it can't get its power to its receiver through the corroded contacts. See the maintenance chapter (para 3-4) for corrective action.

(2) Sun. The upper operating temperature limit—of + 125°F applies to the TEMPERATURE OF THE COMPONENT, not the temperature of the air around it. For example, with the thermometer reading + 85°F in the shade (the air temperature), an item sitting in the direct sun could easily exceed the + 125°F limit. The M122 components must therefore be protected from the direct sun. When doing this, always use a nonmetal covering and allow ventilation as an unventilated box placed over a receiver in the sun will allow the device to get almost as hot as if it were in the direct sun. A few air holes in the sides of the same box could make a 20 or 30 degree difference. The same principle applies to storage facilities. temperatures over + 160°F have been measured in unventilated metal sheds and box cars during hot summer days.

(3) Storage in the field. Do not store the M122 components with the batteries installed even for a day when the temperature is over 80°F during the day. If a refrigerator is available, store the batteries in it during hot weather (or all the time, if possible). Cold storage greatly extends the shelf life of batteries and high temperature storage shortens it (especially if the battery leaks). See shipping and storage, chapter 4, or more details.

d. Blowing Dust and Sand. Blowing dust and sand can cause damage to the external moving parts of the M122 components. The switches, push buttons, transmitter antenna, and binding posts should be given protection during transport and use in such environments. After use under these conditions, clean the items thoroughly (see chapter 3 for maintenance procedures).

e. From Helicopter.

(1) When operating the transmitter from a helicopter, follow the normal procedure for checkout and code selection. To fire the transmitter, place it on the floor of the helicopter in a vertical position and fully extend the antenna. With the door opened, the operator should face the receiver site so he has a clear line of sight. Hold the transmitter and depress the fire button. The transmitter's antenna must not touch any part of the helicopter during transmission.

NOTE

If transmitter's antenna touches any part of the helicopter during transmission, the transmitter's range will be drastically reduced.

(2) The operating range is decreased by bad weather conditions and instructions such as hilly terrain in the signal path. It is increased by having a clear line of sight path. Therefore, the operator should place the receiver in a clear area, if possible, and choose a suitable location and altitude for the helicopter which will provide a clear line of sight from transmitter to receiver.

(3) The M122 is primarily designed to function from land-based stations. However, the capability for helicopter usage (based on limited tests) was successfully demonstrated in the tropics. It has limited application in Arctic use. No data are available for desert application. It is recommended that the M122 be set up for a trial operation to simulate actual operating conditions prior to the actual mission.

f. Dual Priming Method.

(1) An "in-effect" dual priming of charges can be done with the M 122 receiver by wiring two M6 blasting caps in parallel instead of the usual series connection.

NOTE

Use of the parallel "dual-priming is not advised when the ambient temperature is closer than 10°F to either the high or the low operating temperature limit.

(2) The dual priming method may be used providing the connection is limited to two blasting caps wired in parallel, extension wires that do not exceed 100 feet each, and two No. 18 conductor cables. The blasting caps are to be used strictly for dual priming of one charge.

(3) Refer to FM 5-250 and TM 9-1375-213-12 for proper preparation of explosive charges and priming.

CHAPTER 3 MAINTENANCE

Section I. SERVICE UPON RECEIPT OF MATERIEL

3-1. PRECAUTIONS

The components of the M122 are sophisticated and expensive electronic devices. They should be handled, transported, and stored with care. Dropping or severely impacting a component or a battery can disable it. Never leave batteries in a device being stored for more than a few days.

3-2. UNPACKING AND INSPECTION BY OPERATOR

a. When unpacking the items, cut (do not break) the binding straps on the shipping box. Make no attempt to break or wrench apart the straps because of the danger of crushing the box and damaging the equipment inside.

b. Using a flat tipped screwdriver or screwdriver blade of demolition kit knife, remove the screws securing the lid of the wooden shipping box and remove lid. Remove inner packing

materials (as necessary) and lift out the carrying case. If reshipment of the entire M122 is anticipated, retain the wooden box and packing materials. Dispose of steel strapping and (if necessary) the wooden box in accordance with local regulations.

c. Turn the air valve on the carrying case counterclockwise two turns to open it. If there is a hissing sound keep valve open until it stops. Turn air valve clockwise to close it.

d. Open the two bottom case latches (on edge opposite handle) by rotating latch handles upward and then twisting the handles counterclockwise. Swing latches away from their catches to disengage them. Place carrying case on edge, HANDLE FACING UP, and on the ground. While holding the carrying case steady, open the other four latches. Swing the latches away from their catches to disengage them then disassemble the halves of the case and lay them out flat upon the ground.

Section II. OPERATOR MAINTENANCE

3-3. CLEANING

a. The preferred method of cleaning the components and the carrying case is by means of a clean, dry rag.

b. The carrying case may be cleaned with detergent and water if necessary. Remove all contents before such cleaning and allow the case to thoroughly dry before putting them back.

c. If it is necessary to use more than just a rag to clean a transmitter or receiver's exterior surface, use a clean rag dampened with alcohol or water. Do not use any other solvent and NEVER immerse the components. Wipe the component(s) dry afterwards.

NOTE

To clean code number windows on the transmitter, use a cotton swab, or cover the eraser end of a pencil with a clean cloth. Be careful not to place too much pressure on the windows when cleaning them. They can be broken.

3-4. CLEANING BATTERIES AND CONTACTS

a. Before installing a receiver battery, wipe both of its contacts with a clean cloth. If a mercury battery is being used rub both contacts with a clean pencil eraser and then again wipe with a clean rag. This will remove any film exudate that may have developed in storage.

NOTE

- The clear film exudate from mercury batteries is not abnormal and will not affect their capacity but must be cleaned off to assure a proper contact. A few tiny patches of white powder or crystals may be noted. This residue should be removed along with the clear exudate (this will not degrade the battery capacity). A heavy white crusty deposit around the negative contact CAN degrade the battery and is usually indicative of an old or improperly stored battery. If after cleaning, such a battery checks out as good it may be used however only for a short on-duty period (no more than one quarter of its normally expected on-duty life).
- Any alkaline battery found with ANY LIQUID or a HEAVY crusty or crystal exudate should not be used. Any alkaline battery showing ANY EXUDATE should not be used at high (above +80°F) temperatures. At moderate or low temperatures an alkaline battery with a small amount of nonliquid exudate may be cleaned and used for up to half of its normally expected on-duty life. Electronics/supplies issue units which issue batteries are normally equipped with a battery test instrument and can check batteries whenever there is a question of their usability (see para 3-10).

CAUTION

DO NOT USE ELECTRICAL CONTACT CLEANER ON THE BATTERY CONTACTS OF M122 COMPONENTS. THESE CHEMICALS CAN DAMAGE THE PLASTIC COMPONENTS.

b. Battery contacts on both M122 components and the receiver batteries should be inspected and, if necessary wiped with a clean dry rag or a cotton tipped swab (Q-tip or equivalent) when a battery is removed. Wipe the used receiver battery to determine if it leaked and therefore extra attention should be given to the receiver's battery contacts. If more than a dry rag is required to clean the battery's contacts, use an alcohol dampened rag or swab.

c. To clean the transmitter's battery pack connector, reach all the way into the battery compartment with a rag (fig. 3-1). The connector is at the top center of the battery compartment.

d. To clean a transmitter battery pack's connector, use a toothpick or similar small probe to scrape the inside of the metal tube within each hole of the battery's connector.

e. To clean a receiver's internal battery contact, if necessary use a cleaning rag wrapped around a small twig.

3-5. WHEN TO REPLACE BATTERIES

a. Receiver. Expected on-duty service life for the two types of batteries usable in the receiver are given in the tabulated data of paragraph 1-11. The service life applies to fresh batteries. In continuous functioning use (such as on a demolition range), each using unit will get a different service life depending upon number of caps fired, on-duty times, battery age, and the temperatures to which the batteries are subjected. If batteries are being kept on hand for an extended period, assure they do not exceed their shelf life. Nominal shelf life for the receiver battery types in unrefrigerated moderate temperature storage is as follows:

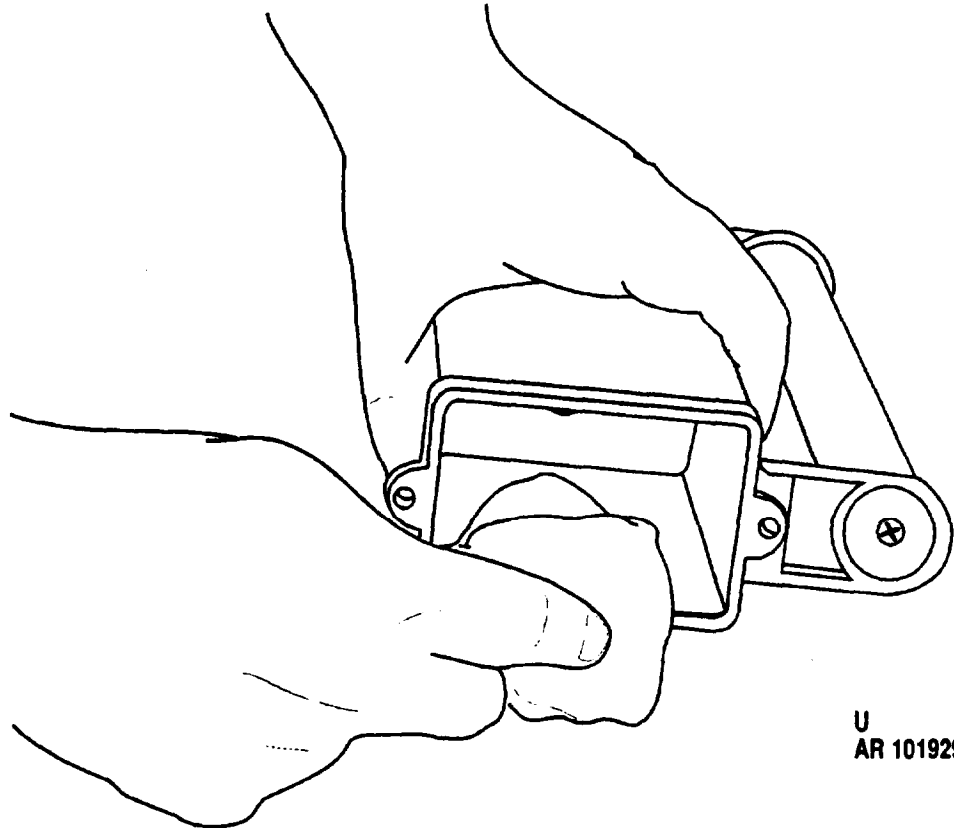

U
AR 101929

Figure 3-1. Cleaning transmitter battery pack connector in battery compartment.

- (1) Alkaline -----36 months.
- (2) Mercury -----24 months.

NOTE

Sealed, refrigerated storage should extend the shelf life of alkaline and zinc-carbon batteries (see shipping and storage chapter 4).

b. Transmitter. Because the transmitter battery is not a commonly stocked item, it should be requisitioned well in advance. Delivery may be slow in OCONUS areas. Where a slow delivery is expected, requisition transmitter battery packs on a time or anticipated usage rate basis. Average useful life at -25°F or + 125°F (temperature extremes) is 1000 transmissions. At more moderate temperatures the average useful life is 1500 transmissions. For low usage transmitters where the

temperature is often above + 80°F , batteries should be requisitioned, on a yearly basis. For a low usage transmitter in areas of more moderate temperature or where the battery is given refrigerated storage when not in use, a new pack should be requisitioned every 18 to 24 months. There is no purpose in keeping a spare battery pack unless the transmitter is being heavily used since the spare will deteriorate from long storage in the same time as the one in use. Wait until the shelf life is nearly over on such packs before requisitioning replacements. Allow adequate time for delivery.

3-6. BATTERY INSTALLATION AND REPLACEMENT

a. Receiver.

- (1) Assure that arming switch is in SAFE position.
- (2) While holding receiver steady, turn battery cap counterclockwise until it disengages. Place cap out of the way.

NOTE

If cap cannot be removed by hand, insert the protruding flange of a second receiver's battery compartment into the slot of the tight battery cap and use the second receiver as a wrench to loosen the cap (fig. 3-2).

(3) Turn receiver to allow old battery to drop out if one is present.

(4) Clean the battery's contacts with a clean rag (fig. 3-3). If the battery's contacts are very dirty corroded, or covered with a film, refer to paragraphs 3-4 and 3-5 for replacement criteria and cleaning instructions.

(5) Clean the battery contacts inside the receiver battery compartment with a clean, dry rag.

(6) If a new battery is being installed, wipe its contacts with a clean rag.

(7) Check polarity markings on battery and insert positive (+) end first into battery compartment (fig. 3-4).

(8) Thread battery cap onto battery compartment and screw it on until a resistance is felt. Turn the battery cap clockwise approximately one more turn to the white index mark located on top of the battery compartment (fig. 3-4) to assure contact.

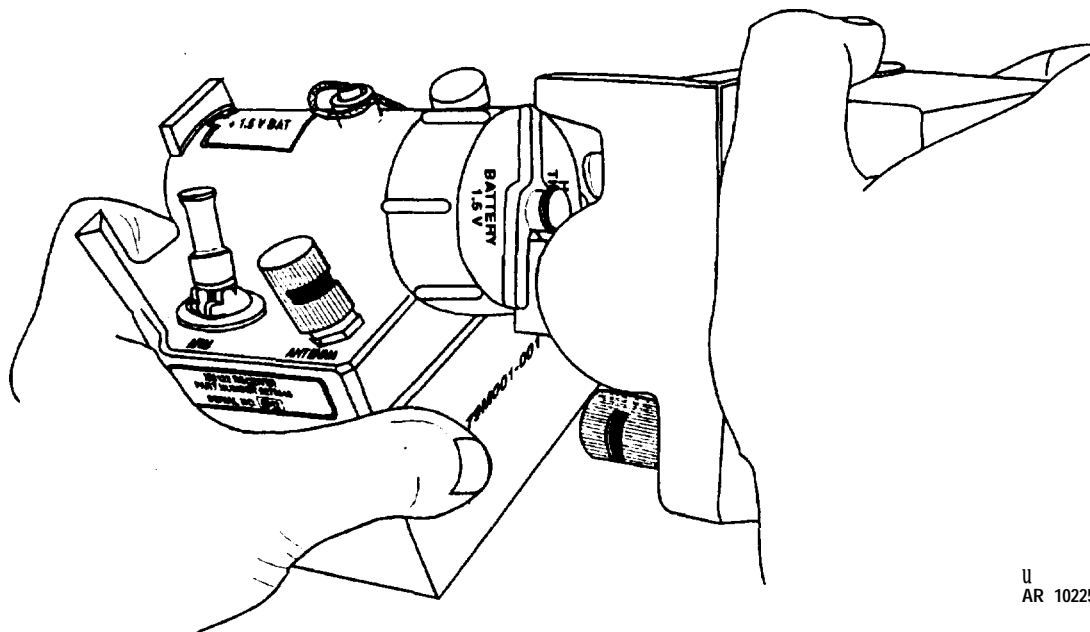

U
AR 102255

Figure 3-2. Removing tight battery cap using the second receiver as wrench.

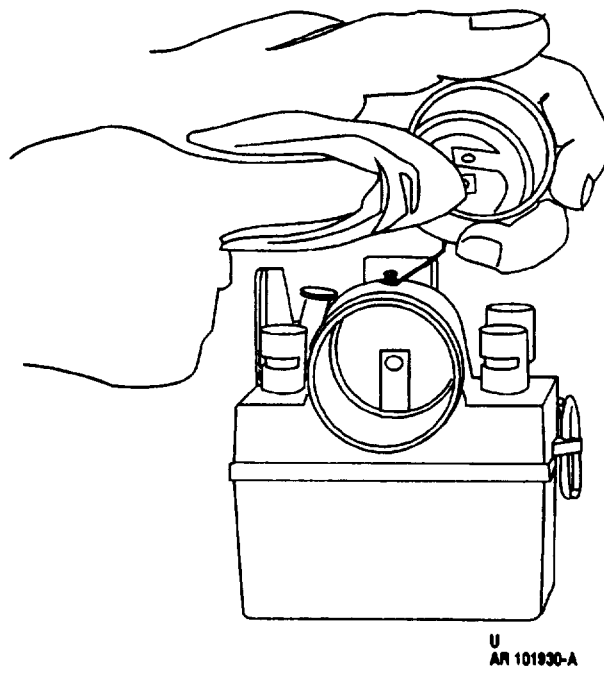

Figure 3-3. Cleaning receiver battery contacts.

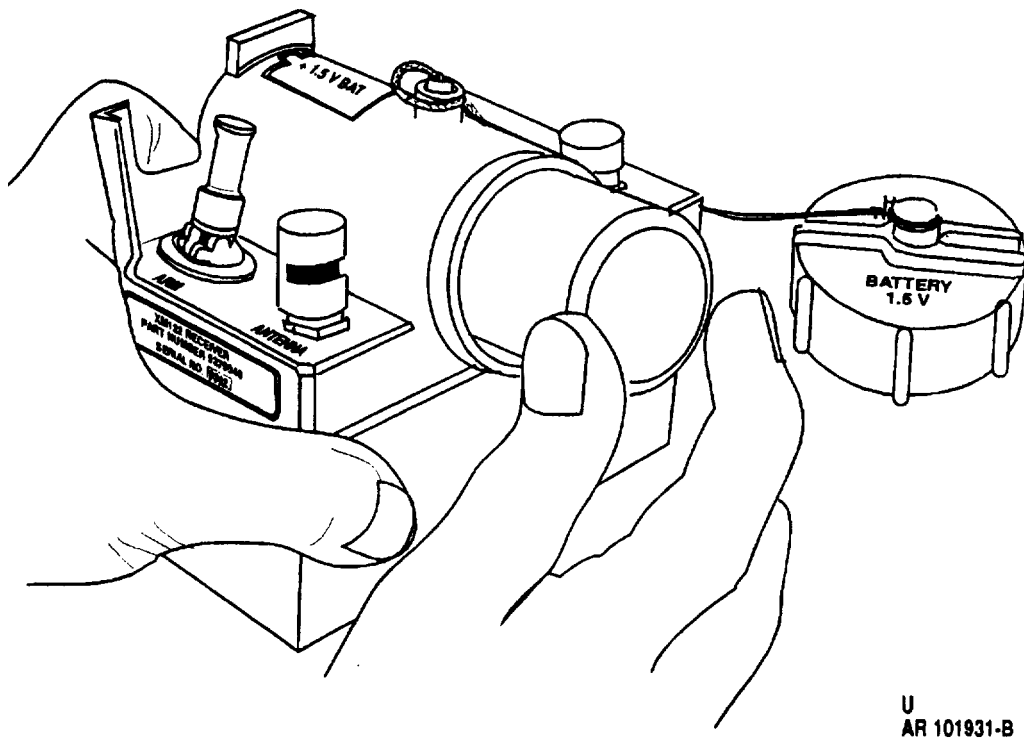

Figure 3-4. Installing receiver battery

NOTE

The receiver will not operate when the battery is put in the wrong way or when the battery cap is not tightened to the index mark.

b. Transmitter.

(1) Secure antenna, if necessary

(2) Invert transmitter and use flat-tip screwdriver to loosen the two captive screws holding end cap on transmitter. Lift off end cap and set aside.

(3) Hold the transmitter steady and manually PULL the battery pack OUT in order to disengage it from the transmitter battery pack contacts. Turn transmitter over and allow old battery pack to FALL out into your hand.

(4) Wipe off battery contact pins inside the battery compartment with a clean rag or cotton-tipped swab. (Refer to paragraph 3-4c if more extensive cleaning is necessary).

(5) Slide new battery pack into the battery compartment, connector end first. When resistance is felt, give the battery pack a little extra push to engage the connector.

(6) Place end cap on transmitter and secure it with the two captive screws using a flat-tip screwdriver. Do not overtighten screws as this could strip the threads.

(7) After replacing transmitter battery pack, use screwdriver to rotate area code switch back and forth through all positions five times.

NOTE

The switch should be exercised occasionally to clean its internal contacts. Battery replacement time is a convenient time to do this.

3-7. DISPOSAL OF USED BATTERIES

WARNING

- BURNING AN ALKALINE OR MERCURY BATTERY CAN

RESULT IN EXPLOSION OF THE BATTERY.

- SHORTING OR ATTEMPTED RECHARGING AN ALKALINE OR MERCURY BATTERY CAN RESULT IN EXPLOSION OF THE BATTERY.

Give consideration to the above WARNINGS when disposing of both transmitter and receiver batteries. Assure they are NOT burned when personnel are located in close proximity; when these batteries explode, metal pieces and hot caustic chemicals are thrown several feet.

3-8. TRANSMITTER ANTENNA REPLACEMENT

a. Built-in Antenna.

(1) If it is secured, loosen antenna cap and pull out antenna enough to gain access to one of the lowest two sections. Use pliers, if necessary

(2) Using flat tip screwdriver, loosen captive screw at base of carrying handle/antenna housing.

(3) Pull out old antenna. Repair it if possible.

NOTE

- If the antenna has a simple bend, try hand straightening it and then rolling the damaged section between two flat boards (e.g., 2 x 4's).
- See training Circular TC 11-5 for additional information on repair of antennas. See b below for an improvised replacement.

(4) Grasp the bottom section of the antenna firmly. Extend the bottom two sections of the repaired or replacement antenna to provide a snug fit between the two sections. Slowly insert the bottom section into the top of transmitter's carrying handle.

(5) When the antenna seats, twist it slowly until it engages the slot in the bottom of the handle.

CAUTION

FINGER TIGHTEN THE SCREW, DO NOT USE A SCREWDRIVER (OVERTIGHTENING COULD DAMAGE THE ANTENNA).

(6) While holding the antenna in position, hand turn the captive screw clockwise until it engages and secures the antenna.

b. Improvising a Replacement Antenna. If the transmitter's antenna becomes badly damaged and a replacement is not available, take the following action:

(1) If the damage is above the antenna's coil and there is at least a foot of antenna left (even if it's bent or crushed), the transmitter may still be used but its range will be reduced. Without the full length of antenna above the coil, the range should still be at least half the normally expected range of a complete antenna.

(2) If the coil is damaged, loosened, or removed from the antenna or if there is less than a foot of antenna left above the coil, a substitute antenna must be rigged:

(a) Obtain a 10 foot length of insulated wire (similar to the receiver's antenna, para 2-3b). If the proper radio frequency (RF) connector (NSN 5935-00-166-6281 or 5935-00-470-2813) is available, solder the conductor to the center contact of the RF connector. Remove the protective cap from the auxiliary antenna connector (fig. 1-2). Secure the RF connector to the auxiliary antenna connector. A push-twist motion is required to do so.

Disconnect the RF connector after assuring it works properly. If this is done, skip step (b) below and to step (c) If the RF connector is not available and if possible, obtain an alligator clip or a similar electrical clamp suitable for grasping the antenna below the coil.

(b) Strip half an inch of insulation from one end of the wire and secure the clip or clamp to the wire. If no clip or clamp is available, strip about four inches of insulation from one end of the wire.

(c) At the desired transmitter location, secure the wire in a vertical attitude, stripped end down. Take or tie the antenna in position with string or similar item, not wire.

Do not tie the antenna wire itself around anything since this will effectively shorten the antenna and reduce the operational range.

NOTE

The transmitter antenna wire MUST be set up vertically. Laying it out on the ground (as can be done with the receiver) will drastically reduce the unit's range.

(d) If the RF connector is to be used, use a flat tip screwdriver or screwdriver blade of demolition kit knife to loosen captive screw at base of carrying handle/antenna housing. Pull out the remains of the original antenna. Do not discard the antenna if there is any hope of repairing it.

(e) Connect the antenna wire to the transmitter as follows:

1. By use of the RF connector (fig. 3-5 a).

2. Secure the antenna's clip or clamp to the remains of the antenna BELOW the coil (fig. 3-5 b.)

3. Tie the stripped end of the antenna wire tightly around the remains of the antenna BELOW the coil. Tape or tie with a string to assure a good contact (fig. 3-5 c.)

NOTE

Methods 2 and 3 above will reduce the effective range of the transmitter.

3-9. CHECKOUT PRIOR TO USE

a. General. Checkout procedures should be undertaken at the following time:

(1) As soon after issue as practicable.

(2) Prior to any mission when the M122 components have been in storage or otherwise inactive for more than a few days.

(3) After dropping or impacting the units.

(4) After cleaning a battery compartment that has battery leakage or corrosion on its battery contacts or when a mercury battery is being used in the receiver.

(5) Prior to ALL missions where time and circumstances permit conducting the test. This will give added assurance of mission success.

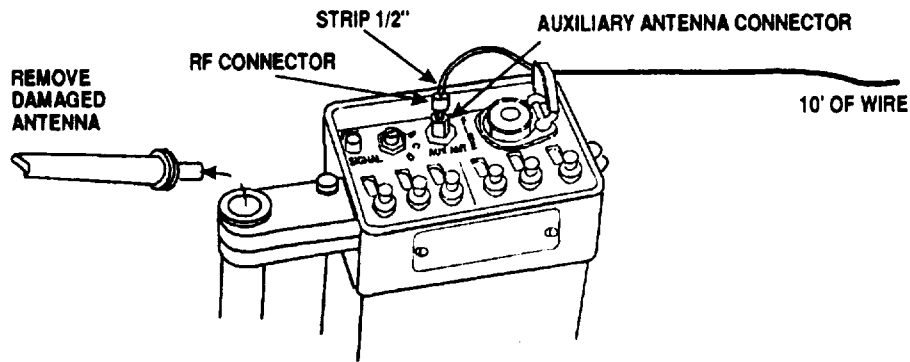

(a) SOLDER CONDUCTOR TO RF CONNECTOR

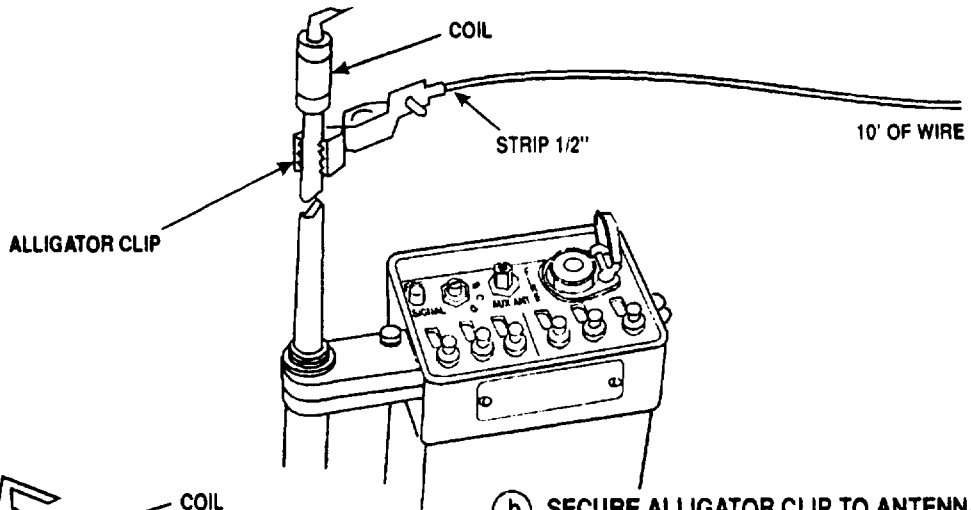

(b) SECURE ALLIGATOR CLIP TO ANTENNA

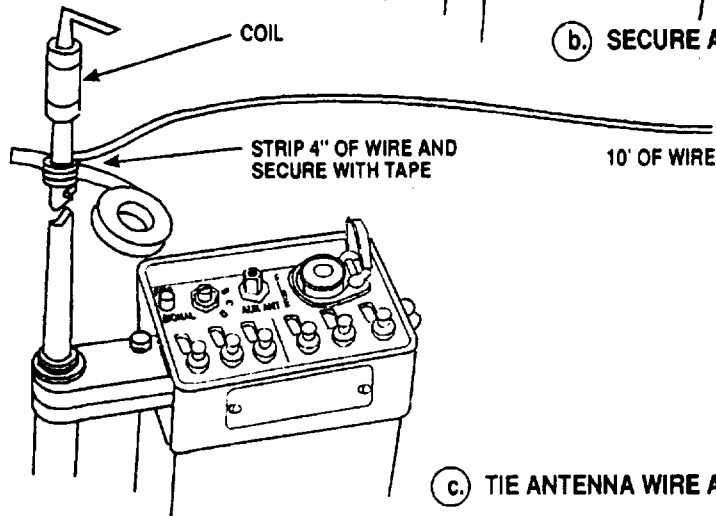

(c) TIE ANTENNA WIRE AROUND ANTENNA

U
AR6435

Figure 3-5. Improvising a replacement antenna.

b. Procedures.

WARNING

- DO NOT UNDERTAKE THIS PROCEDURE IN THE SAME AREA OR AT THE SAME TIME THAT OPERATIONS ARE BEING CONDUCTED IN WHICH OTHER M122 FIRING DEVICES ARE BEING USED.
- KEEP THE TRANSMITTER AT LEAST 100 FEET FROM ANY ELECTRIC BLASTING CAPS (OR OTHER ELECTRO-EXPLOSIVE DEVICES) DURING CHECKOUT OR USE,

c. Transmitter. Perform self-test as follows:

NOTE

For transmitter self-test, the area code switch may be in any position.

- (1) Set code to 000000 by depressing the six push button switches,
- (2) Unscrew antenna cap,
- (3) Extend the antenna (fig. 2-1).

WARNING

AVOID CONTACT WITH
ANTENNA WHEN PRESSING

FIRE BUTTON. A SLIGHT BURN CAN RESULT FROM TOUCHING THE ANTENNA WHEN A SIGNAL IS BEING TRANSMITTED. ADDITION, THE TRANSMISSION RANGE WILL BE REDUCED.

(4) Lift FIRE button cover and depress FIRE button for 5 seconds while observing FIRE SIGNAL lamp.

(a) Lighting of FIRE SIGNAL lamp indicates transmitter is in working order and may therefore, be used to test operability of receiver.

(b) If FIRE SIGNAL lamp does not light, the most probable cause is a weak battery pack or corroded battery contacts. See paragraphs 3-4, 3-6, and 3-10 for corrective maintenance. After correcting deficiencies, again perform self-test as above.

(5) Retract and secure antenna.

NOTE

If a transmitter appears defective and actions described in (4) above do not restore unit to serviceable condition, the problem may be only the FIRE SIGNAL lamp. If time and circumstances permit, try to use the apparently defective transmitter to actuate a receiver that has been successfully checked out with another transmitter. If it actuates the receiver, it is good and may be used. The lamp is not critical to the OPERATION of the transmitter. It is only supposed to light when power is fed to the antenna. The lamp is not replaceable; a good transmitter with only a defective lamp maybe used.

d. Receiver. Assure that receiver's arming switch is in SAFE position and the battery cap is securely tightened down. Test receiver as follows:

(1) Obtain a 10-foot length of insulated wire. Strip an inch of insulation from one end. Insert and secure the stripped end into receiver's antenna binding post.

(2) Place receiver on ground or table⁴ and extend antenna vertically, securing it in that attitude (e.g. tape the top to a tree branch).

(3) The operation of the receiver may be checked by either of the following methods:

(a) **NOT connecting ANYTHING to the blasting cap binding posts and observing the receiver's FIRE SIGNAL lamp during functioning.**

(b) Connecting a blasting cap to the blasting cap binding posts. Set the cap itself safely away from receiver (for example, under a sandbag) and personnel. The cap will function if the device is working properly. The receiver's FIRE SIGNAL lamp may NOT work if a cap is connected to the receiver. Use the procedures in paragraph 2-3 to set up the cap prior to functioning.

(c) Use of a flash bulb or low voltage light bulb (such as a #313, 28 volt panel bulb) across blasting cap binding posts as in (b) above is an acceptable alternate method of checkout and a safer practice since no explosives are involved.

NOTE

The flash bulb (or single blasting cap) just checks the basic operation of the receiver, not its capacity. The capacity of the receiver can only be checked by actually firing the rated number of caps or setting up and using an electrical test rig (which cannot be done at user level). As a quick check, the flash bulb (or single cap) is quite acceptable. If there is any doubt about the receiver's capacity, a full load of caps should be used for a complete test.

(4) Use a transmitter that has been self-tested and determined to be in working order. Set area code and numbers on transmitter to the letter and number settings indicated on the receiver to be tested (fig. 1-4). Settings are stamped into receiver body adjacent to identification plate.

(5) Hold receiver steady lift and move arming switch to ARM position.

WARNING

AVOID CONTACT WITH TRANSMITTER ANTENNA WHEN PRESSING FIRE BUTTON. A SLIGHT BURN CAN RESULT FROM TOUCHING THE ANTENNA WHEN A SIGNAL IS BEING TRANSMITTED. IN ADDITION, THE TRANSMISSION RANGE WILL BE REDUCED.

(6) After waiting 8 minutes for device to arm, unscrew antenna cap and fully extend the antenna (fig. 2-1). With the transmitter at least 6 feet away from the receiver, lift the FIRE button protective cover and depress the FIRE button for at least 5 seconds. Observe the FIRE SIGNAL lamp on the receiver (or blasting cap from a safe distance).

(7) Lighting of the receiver's FIRE SIGNAL lamp (or firing of the cap) indicates receiver is in working order.

NOTE

After receiver is functioned (with or without a cap), it requires 2 to 4 minutes to recharge before it can be functioned again. Always allow the full 4 minutes in cold temperatures.

(8) If FIRE SIGNAL lamp does not light or the cap does not function, it is probably the result of a weak battery, loose battery cap, or corroded battery contacts. Set arming switch to SAFE and disconnect wires. If used, short cap wires by twisting wires together. See paragraphs 2-6, 3-4, and 3-10 for required corrective maintenance. After maintenance or replacing the battery, go to step (1) above.

(9) If a receiver is found defective and the maintenance does not restore the unit to serviceable condition, see paragraph 2-6 for disposition.

(10) If receiver checked out properly set arming switch to SAFE and disconnect wire(s). Recover antenna wire for use with the same receiver or other receivers.

3-10. CARRYING CASE REPAIR

Local, expedient repair of the carrying case by operating personnel is authorized. Expedient repair of a cut or gash may be done by use of a piece of olive drab cloth backed tape. More extensive *or* permanent repair may be undertaken at the discretion of the officer in charge.

3-11. OPERATOR QUARTERLY CHECKOUT/PMCS

All items not in regular service should be checked out every quarter by having a good bat-

tery pack inserted in the transmitter and one receiver per paragraphs 3-4 and 3-6. Then perform an operational check per paragraph 3-9. If units check out properly remove batteries then pack units and batteries for storage. If either unit fails to function properly the most probable cause is old batteries, corroded contacts on batteries, or in the unit that did not check out. Have battery checked by Organizational Maintenance per section III. Repeat cleaning and installation steps per paragraph 3-6. Repeat operational checks per paragraph 3-9. If this does not correct the situation, the offending unit should be disposed of in accordance with local regulations.

Section III. ORGANIZATIONAL MAINTENANCE

NOTE

If necessary, general maintenance is to be done in accordance with the basic Demolition Materials Operator's Manual, TM 9-1375-213-12. The same applies to any other authorized operations not detailed in this supplemental manual.

NOTE

The transmitter may not function properly when used with a pack having a voltage measuring less than 15.0 volts under load. The lower the battery's voltage, the lower the power that can be provided the transmitter. For correct voltage reading, voltage must be checked under load.

3.12. BATTERY/BATTERY PACK

a. General. The only organizational maintenance Required for the 122 is testing the batteries at time of issue. It is intended that this be done by issuing supply group. Batteries in service may also be tested upon request of user personnel.

b. Transmitter Pack. Test the pack volts e at room temperature (+ 60° F to + 80° F +15°C) under load using Test Jack #10 (approximately 30 ohms) of TS 183()/U. A fresh pack will measure 17.0 volts or more under load and is expected to have an estimated operating life of 1000 transmitter firings over the temperature range -25°F (-32°C) to + 125°F (+52°C). A pack measuring 16.5 volts under load is expected to have an operating life that is one half that of a fresh pack under certain circumstances. The absolute minimum pack voltage under load for short term useage e is 15.0 volts. In this case the operator should obtain a replacement pack as soon as possible.

c. Receiver Batteries. Test receiver batteries at room temperature (+ 60°F to + 80°F. + 15°C to + 27°C) under load using Test Jack #3 (approximately 6 ohms) of TS 183()/U. Table 3-1 gives test parameters for the batteries including expected on-duty life of the battery

NOTE

- On-duty life is affected primarily by battery type, battery voltage under load, battery condition, temperature, and the number of blasting caps fired. Therefore, under certain circumstances the actual on-duty life could deviate significantly from the expected values given in paragraph 1-11.
- A fresh alkaline battery (BA 3030) should measure 1.48 volts under load and provide the maximum on-duty life, (see para 1-11). The receiver will not function properly when used with a battery having a voltage measuring less than 1.2V

Table 3-1. Battery Test Parameters with battery at room temperature
 (between +60° and +80°F) under load.

Battery		Voltage of a fresh battery (see note 1)	Minimum voltage for general use (see note 2)	Absolute minimum voltage (see note 3)	Minimum voltage for low temperature (-25°F, -32°C) use
	<u>Alkaline</u> BA 3030	1.48V	1.35V	1.20V	1.48V (20 days on-duty life is expected)
Alternate Battery	<u>Mercury</u> BA-1030	1.30V	1.25V	1.20V	Do not use below +50°F (10°C)

1. Expected on-duty life of a fresh battery is given in paragraph 1-11.
2. Expected on-duty life is 72 hrs at the lower battery operating temperature extreme given in paragraph 1-11.
 Expected on-duty life at moderate temperature (+ 75°F + 24°F) is about 50% of fresh battery on duty life, see note 1 above.
3. Expected on-duty life is 8 hrs at the lower battery operating temperature extreme given in paragraph 1-11.

CHAPTER 4 SHIPPING AND STORAGE

4-1. SHIPMENT

a. General. The electronic components of the M122 are both sophisticated and expensive. They are ruggedized but should still be accorded the maximum possible protection during shipment.

b. Procedure.

(1) When shipping the system, use the contoured and padded carrying case provided.

NOTE

Except for local transportation to an operational site, assure batteries are removed from both transmitter and receiver prior to shipment. For short trips, the batteries may be put in the contoured recesses provided in the carrying case. For long distance shipment, pack them in plastic bags in separate boxes. The plastic bag will restrict the

flow of any leakage that may occur. Use crumpled newspapers or other suitable materials to pad the batteries and keep them immobilized to prevent movement during shipment.

(2) For long distance or rough terrain shipment, overpack case in wooden box as used in initial shipping.

(3) When air shipping the case, assure the air valve is open prior to shipment by turning it counterclockwise (fig. 4-1). Close it (turn it clockwise) upon completion of the air shipment. This applies to local helicopter shipment as well as longer trips.

(4) When shipping a transmitter or receiver separately, remove battery and pack the item(s) well using crumpled newspapers or other suitable cushioning material in a sturdy box. Use the packing material to keep items separated. If possible, use a wooden or metal box (ammunition can or box) for maximum protection.

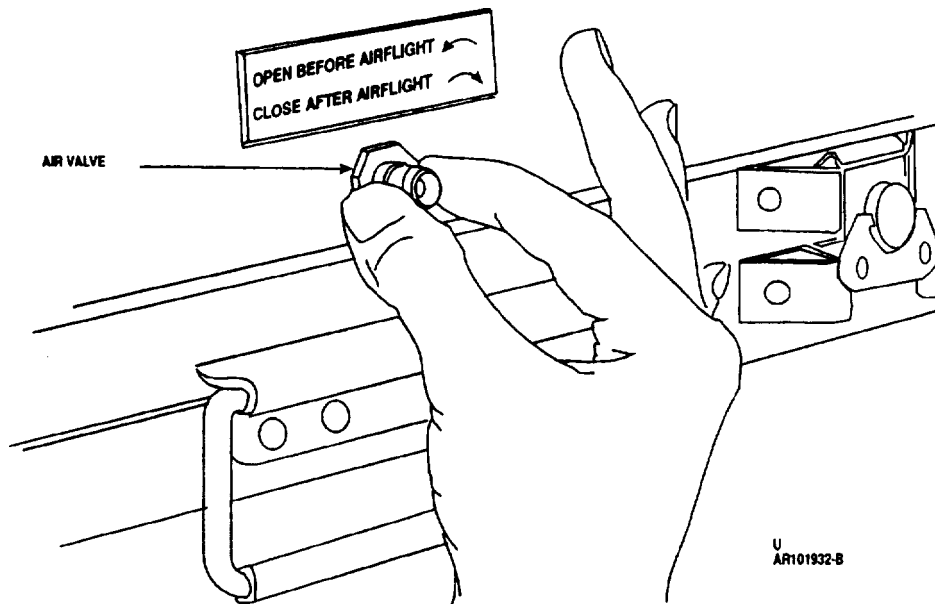

Figure 4-1. Operating air valve.

4-2. STORAGE

a. General. The components of the M122 are expensive electronic devices and are designed to initiate explosives remotely. This makes secure storage necessary.

b. Components.

(1) . NEVER store either transmitter or receiver with battery installed for more than a few days. This is especially important in hot weather when batteries are prone to leakage.

(2) Provide the best cool, dry storage available. Whenever possible, store M122 components in the fitted carrying case. For extended storage place one or two fresh desiccant (silica gel) bags in the carrying case, if available. Always assure the case's air valve is closed.

(3) Use a plastic bag to wrap individual components to be stored for an extended period. If available, pack a fresh desiccant bag with each component.

c. Batteries. If available, use a refrigerator for long-term storage of batteries. This will

greatly extend the shelf life of the batteries and they will have more power available when put into service. Wrap the batteries in plastic and seal with tape prior to refrigeration storage. Take the batteries from the refrigerator at least two hours before use to allow them to adjust to the warmer room temperatures.

4-3. SHIPPING AND STORAGE DATA

Carrying case with one transmitter, 10 receivers and all necessary batteries,

Weight ----- 35 lb (16.6 kg)

Cube ----- 2.75 cu ft (0.08 cu m)

DOT shipping class, etc., not applicable, item contains no explosives.

NOTE

Data above are for the carrying case without overpack. Data for overpacked box (as issued) are given in tabulated data, paragraph 1-11.

APPENDIX A REFERENCES

A-1. PUBLICATIONS INDEX

The following publication index should be consulted frequently for the latest changes or revisions of references given in this appendix and for new publications relating to the material covered in this manual:

Consolidated Index of Army Publications and Blank Forms DA Pam 25-30

A-2. TECHNICAL MANUALS

Land Mines TM 9-1345-203-12 &P
Demolition Materials TM 9-1375-213-12
Demolition Materials TM 9-1375-213-34
Unconventional Warfare Devices and Techniques TM 31-200-1
The Army Maintenance Management System (TAMMS) DA Pam 738-750

A-3. ARMY REGULATIONS

Reporting of Transportation Discrepancies in Shipment..... AR 55-38
Malfunctions Involving Ammunition and Explosives AR 75-1
Accident Reporting and Records AR 385-40
Policies and Procedures for Firing Ammunition for Training,
Target Practice and Combat AR 385-63
Fire Prevention and Protection AR 420-90
Report of Item and Packing Discrepancies AR 735-11-2

A-4. DOCTRINAL, TRAINING AND ORGANIZATIONAL PUBLICATIONS

Explosives and Demolitions FM 5-250
Boobytraps FM 5-31
Engineer Field Data FM 5-34
Explosive Ordnance Disposal *Service* and Unit Operations. FM 9-15
Special Forces Operations FM 31-20
Know How to Repair and Fabricate Antennas. TC 11-5

A-5. BLANK FORMS

US Army Accident Investigation Report DA Form 285
Recommended Changes to Publications and Blank Forms DA Form 2028-2
Fire Report DA Form 3985
Discrepancy in Shipment Report SF 361
Report of Discrepancy (ROD)..... SF 364

TM 9-1375-213-12-3
TO 11A20-15-1

THIS PAGE INTENTIONALLY LEFT BLANK

APPENDIX B PACKING MATERIALS, ACCESSORIES, AND TOOLS

Section I. INTRODUCTION

B-1. Scope

This appendix lists packing materials, accessories, and tools required for the performance of operator and unit maintenance of the M122 firing device.

B-2. General

This appendix is divided into the following sections:

a. Section II - Packing Materials and Accessories. A list of packing materials and accessories authorized for the performance of maintenance at the unit level.

b. Section III - Special Packing Tools. A list of special packing tools and equipment authorized for the performance of maintenance at the unit level.

B-3. Explanation of Columns

The following provides an explanation of columns in Section II and III.

a. Part Number. Indicates the primary number used by the manufacturer which controls the design and characteristics of the item. Drawings can be obtained from originating source (see CAGE Code).

b. Contractor and Government Entity Code (CAGE) - (Formerly known as Federal Supply Code for Manufacturers (FSCM)). A five-digit code used to identify the manufacturer, distributor, or Government agency/activity that supplies the item.

c. Figure Number. This column lists the number of the figure where the item is identified/located.

if. Description. Indicates the Federal item name and any additional description of the item required.

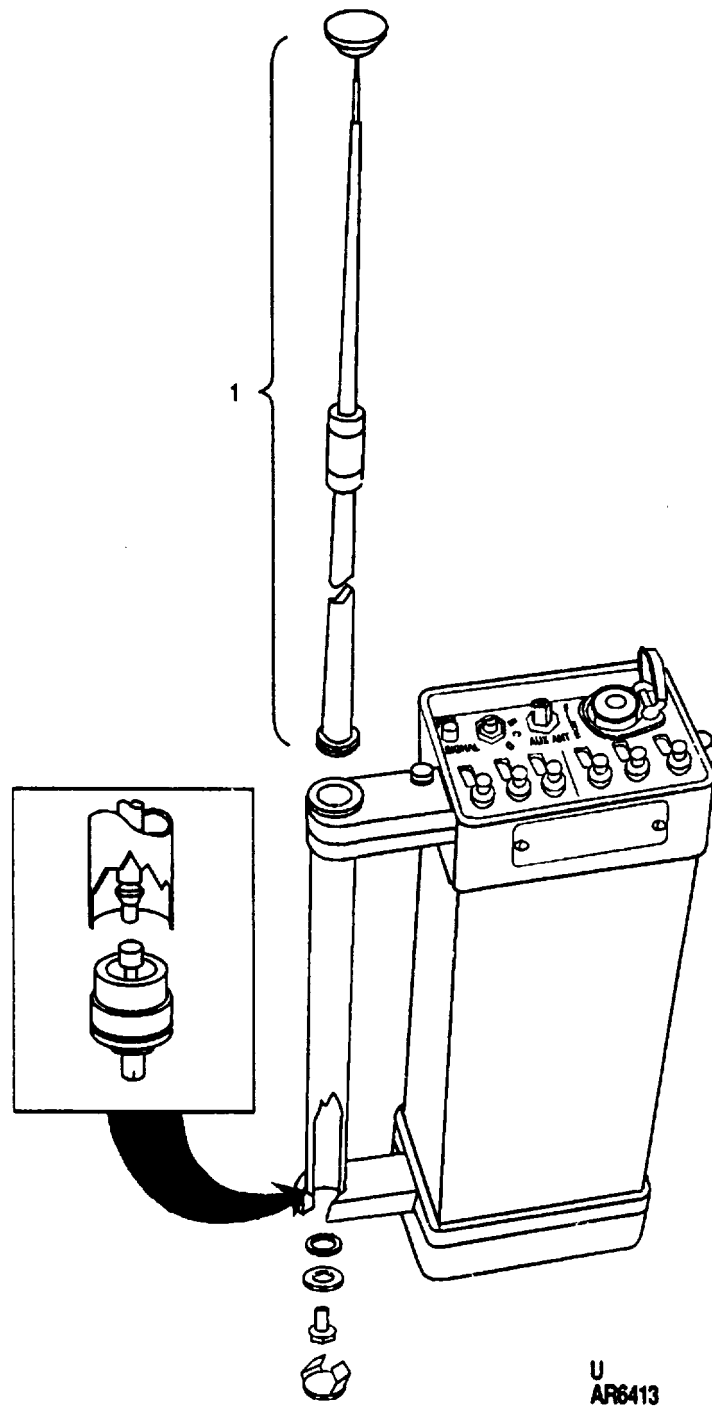

U
AR6413

Figure B-1. CONTROL, REMOTE, FIRING DEVICE

Section II. PACKING MATERIALS, AND ACCESSORIES

Part No. (Dwg No.)	CAGE Code	Figure No.	Description	UI/UM
9324624	19200	B - 1 Item 1	FIGURE B1. CONTROL, REMOTE, FIRING DEVICE; (19203) 9252773 (1375-01-028-4077) ANTENNA: (5985-01-101-3955)	EA

Section III. SPECIAL PACKING TOOLS

NOT APPLICABLE

TM 9-1375-213-12-3
TO 11A20-15-1

THIS PAGE INTENTIONALLY LEFT BLANK

APPENDIX C

MAINTENANCE ALLOCATION CHART

Section I. INTRODUCTION

C-1. GENERAL

a. This section provides a general explanation of maintenance and repair functions authorized at various maintenance categories.

b. The Maintenance Allocation Chart (MAC) in section II designates overall authority and responsibility for the performance of maintenance functions on the identified end item or component. The application of the maintenance functions to the end item or component will be consistent with the capacities and capabilities of the designated maintenance categories,

c. Section III lists the tools and test equipment required for each maintenance function as referenced in section II.

d. Section IV contains supplemental instructions and explanatory notes for a particular maintenance function.

C-2. MAINTENANCE FUNCTIONS

Maintenance functions will be limited to and defined as follows:

a. Inspect. To determine the serviceability of an item by comparing its physical, mechanical, and/or electrical characteristics with established standards through examination.

b. Test. To verify serviceability by measuring, pneumatic, hydraulic, or electrical characteristics of an item and comparing those characteristics with prescribed standards,

c. Service. Operations required periodically to keep an item in proper operating condition, i.e., to clean, to preserve, to drain, to paint, or to replenish fuel, lubricants, chemical fluids, or gases.

d. Remove/Install. To remove and install the same item when required to perform service or other maintenance functions. Install may be the act of emplacing, seating, or fixing into position a spare, repair part, or component or assembly, in a manner to allow the proper functioning of the end item.

e. Replace. To remove an unserviceable item and install a serviceable counterpart in its place,

f. Repair. The application of maintenance services¹ including troubleshooting², removal/installation, and disassembly/assembly³ procedures, and maintenance actions⁴ to identify troubles and restore serviceability to an item by correcting specific damage, fault, malfunction, or failure in a part, subassembly, component, end item, or system,

C-3. EXPLANATION OF COLUMNS IN MAC, SECTION II

a. Column 1, Group Number, Column 1 lists functional group code numbers, the purpose of which is to identify maintenance significant components, assemblies, subassemblies, and modules with the next higher assembly.

¹Services - inspect, test, service, adjust, aline, calibrate, and/or replace.

²Troubleshooting - the process of investigating and detecting the cause of equipment malfunctioning; the act of isolating a fault within a system or unit under test,

³Disassemble/assemble - encompasses the step-by-step taking apart (or breakdown) of a spare/functional group coded item to the level of its least component identified as maintenance significant (i.e., assigned as SMR code) for the level of maintenance under consideration.

⁴Actions - welding, grinding, riveting, straightening, facing, remachining, and/or resurfacing

b. Column 2, Component/Assembly. Column 2 contains the names of components, assemblies, subassemblies, and modules for which maintenance is authorized,

c. Column 3, Maintenance Function. Column 3 lists the functions to be performed on the item listed in Column 2. (For detailed explanation of these functions, see paragraph C-2 "Maintenance Functions" on page C-1.)

d. Column 4, Maintenance Level. Column 4 specifies, by the listing of a work time figure in the appropriate subcolumn(s), the level of maintenance authorized to perform the function listed in column 3. This figure represents the active time required in hours to perform that maintenance function at the indicated level of maintenance. If the number of complexity of the tasks within the listed maintenance function vary at different maintenance levels, appropriate work time figures will be shown for each level. The work time figure represents the average time required to restore an item (assembly, subassembly, component, module, end item, or system) to a serviceable condition under typical field operation conditions. This time includes preparation time, troubleshooting time, and quality assurance/quality control time in addition to the time required to perform the specific tasks identified for the maintenance functions authorized in the maintenance allocation chart. The symbol designations for the various maintenance categories are as follows:

- C - Operator or crew
- O - Unit maintenance
- F - Direct support maintenance
- H - General support maintenance
- D - Depot maintenance

e. Column 5, Tools and Equipment. Column 5 specifies, by code, those common tool

sets (not individual tools) and special tools, TMDE, and support equipment required to perform the designated function.

f. Column 6, Remarks. This column shall, when applicable, contain a lettercode, in alphabetic order, which shall be keyed to the remarks contained in section IV.

C-4. EXPLANATION OF COLUMNS IN TOOL AND TEST EQUIPMENT REQUIREMENTS, SECTION 111

a. Column 1, Reference Code. The tools and test equipment reference code correlates with a code used in the MAC, section II, column 5.

b. Column 2, Maintenance Level. The lowest level of maintenance authorized to use the tool or test equipment.

c. Column 3, Nomenclature. Name or identification of the tool or test equipment,

d. Column 4, National/NATO Stock Number. The national/NATO stock number of the tool or test equipment.

e. Column 5, Tool Number. The manufacturer's part number,

C-5. EXPLANATION OF COLUMNS IN REMARKS, SECTION IV

a. Column 1, Reference Code. The code recorded in column 6, section II.

b. Column 2, Remarks. This column lists information pertinent to the maintenance function being performed as indicated in the MAC, section II.

Section II MAINTENANCE ALLOCATION CHART (MAC)

(1) Group Number	(2) Component Assembly	(3) Maintenance Function	(4) Maintenance Level Unit			(5) Tools and Equipment	(i) Remarks
			C	O	D		
01	Firing Device Demolition: M122	Inspect	0.1	—	—	—	
		Test	0.4	—	—	—	
		Unpack	0.1	—	—	—	
		Repack	0.1	—	—	—	
		Clean	0.2	—	—	—	
		Mark	0.1	—	—	—	
		Install	0.3	—	—	—	
		Adjust	0.3	—	—	—	
02	Transmitter	Inspect	0.1	—	—	—	
		Test	0.3	—	—	—	
		Unpack	0.1	—	—	—	
		Repack	0.1	—	—	—	
		Clean	0.3	—	—	—	
		Mark	0.1	—	—	—	
		Adjust	0.2	—	—	—	
		Repair	0.5	—	—	—	
		Replace	—	—	0.1	—	
	Antenna (Transmitter)	Inspect	0.1	—	—	—	
		Unpack	0.1	—	—	—	
		Clean	0.1	—	—	—	
		Repair	0.2	—	—	—	
03	Receiver	Inspect	0.1	—	—	—	
		Test	0.3	—	—	—	
		Unpack	0.1	—	—	—	
		Repack	0.1	—	—	—	
		Clean	0.3	—	—	—	
		Install	0.3	—	—	—	
		Adjust	0.3	—	—	—	
		Replace	—	—	0.1	—	

Section II. MAINTENANCE ALLOCATION CHART (MAC) - Continued

(1) Group Number	(2) Component Assembly	(3) Maintenance Function	(4) Maintenance Level unit			(5) Tools and Equipment	(6) Remarks
			c	0	D		
04	Battery Pack (Transmitter)	Inspect	0.1		—	—	
		Test	—	0-2	—	—	
		Unpack	0.1	—	—	—	
		Repack	0.1	—	—	—	
		Clean	0.2	—	—	1	
		Install	0.1	—	—	—	
		Replace	0.1	—	—	—	
05	Battery (Receiver)	Inspect	0.1	—	—	—	
		Test	—	0.2	—	—	
		Unpack	0.1	—	—	—	
		Repack	0.1	—	—	—	
		Clean	0.1	—	—	1	
		Install	0.1	—	—	—	
		Replace	0.1	—	—	—	
06	Wire, Antenna (Receiver)	Inspect	0.1	—	—	—	
		Unpack	0.1	—	—	—	
		Repack	0.1	—	—	—	
		Clean	0.1	—	—	—	
		Install	0.2	—	—	—	
		Replace	0.3	—	—	—	
07	Carrying Case	Inspect	0.1	—	—	—	
		Unpack	0.1	—	—	—	
		Repack	0.1	—	—	—	
		Clean	0.1	—	—	—	
		Mark	0.1	—	—	—	
		Repair	0.2	—	—	—	
08	Packing	Inspect	0.1	—	—	—	
		Clean	0.1	—	—	—	

Section III. TOOLS AND TEST EQUIPMENT REQUIREMENTS

Reference Code	Maintenance Level	National Stock Number	Tool Description
1	C, 0	5110-00-162-2205	KNIFE, POCKET: Special Tools, can opener, punch blade, screwdriver and bottle opener, w/clevis, one cutting blade, lg of blade 3-1/4 in. MIL-K-818 (81349)

SECTION IV. MAINTENANCE ALLOCATION CHART (MAC) REMARKS

Reference Code	Remarks
NOT APPLICABLE	

NOTE

Unless otherwise noted, no higher level (direct support, general support, or depot) will be performed. Guidance from depot will be provided by Rock Island, IL.

TM 9-1375-213-12-3
TO 11A20-15-1

THIS PAGE INTENTIONALLY LEFT BLANK

APPENDIX D

EXPENDABLE AND DURABLE ITEMS LIST

SECTION I. INTRODUCTION

D-1. SCOPE

This appendix lists expendable and durable items you will need to operate and maintain the M122 firing device.

These items are authorized to you by CTA 50-970, Expendable Items (except Medical, Class V, Repair Pints, and Heraldic items).

D-2. EXPLANATION OF COLUMNS

The following provides an explanation of columns in Section IL

a. Column (1) - Item number. This number is assigned to the entry in the listing for referencing when required.

b. Column (2) - Level. This column identifies the lowest level of maintenance that requires the listed item.

O - Unit Maintenance
F - Direct Support Maintenance
H - General Support Maintenance

c. Column (3) - National Stock Number. This is the National Stock Number (NSN) assigned to the item; use it to request or requisition the item.

d. Column (4) - Description. Indicates the federal item name and, if required, a description to identify the item. The last line for each item indicates the Commercial and Government Entity Code (CAGEC) parentheses followed by the part number.

e. Column (5) - Unit of Measure (U/M)/Unit of Issue (U/I). This column indicates the measure used in performing the actual maintenance function. This measure is expressed by a two-character alphabetical abbreviation (i.e., EA, IN., PR). If the unit of measure differs from the unit of issue, as shown in the Army Master Data File (AMDF), requisition the lowest unit of issue that will satisfy your requirements.

SECTION II. EXPENDABLE AND DURABLE ITEMS LIST

(1) Item Number	(2) Level	(3) National Stock Number	(4) Description	(5) (U/M)/ (u/I)
1	o	6810-00-543-7415	ALCOHOL, DENATURED: Grade III (81348) OE760	gl
2	0	6515-00-303-8250	APPLICATOR, DISPOSABLE: Cotton tipped (81348) GGG-A-616	bx
3	0	6135-01-110-3516	BATTERY, NONRECHARGEABLE: Alkaline, 18 V (19203) 9296723	ea
4	0	6135-00-835-7210	BATTERY, NONRECHARGEABLE: Alkaline, 1.5 V (81349) BA-3030/U	pg
5	0	6135-00-125-5265	BATTERY, NONRECHARGEABLE: Mercury, 1.35 V (81349) MILB18	pg
6	0	5935-00-166-6281	CONNECTOR, PLUG, ELECTRICAL: (81349) M39012/55-3007	ea
7	0	7920-00-205-1711	RAG, WIPING Cotton, unbleached and mixed colors (64067) 7920-00-205-1711	be
8	0	7510-00-266-5016	TAPE, PRESSURE-SENSITIVE ADHESIVE: Cloth backed, olive drab lusterless, Type III, class 1,2 in. w (81348) PPP-T-60	ro
9	0	6145-00-542-3968	WIRE, ELECTRICAL: Solid conductor, No. 20 AWG (18876) 9139656-1	ft

By Order of the Secretaries of the Army and the Air Force:

Official:

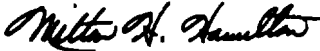
MILTON H. HAMILTON
*Administrative Assistant to the
Secretary of the Army*
07180

GORDON R. SULLIVAN
*General, United States Army
Chief of Staff*

Official:

RONALD W; YATES
General, United States Air Force
Commander, Air Force Materiel Command

MERRILL A. McPEAK
*General, United States Air Force
Chief of Staff*

Distribution:

Army: To be distributed in accordance with DA Form 12-40-E, Block 0632, requirements for TM 9-1375 -213-12-3/T0 11A20-15-1.

Air Force: Requisition Number 4-42017-LC.

RECOMMENDED CHANGES TO EQUIPMENT TECHNICAL PUBLICATIONS



THEN JOT DOWN THE
DOPE ABOUT IT ON THIS
FORM. CAREFULLY TEAR IT
OUT. FOLD IT AND DROP IT
IN THE MAIL.

STROKE OUT THIS TEXT WHEN YOU WRITE WITH THIS PUBLICATION?

FROM (PRINT YOUR UNIT'S COMPLETE ADDRESS)

DATE SENT

PUBLICATION NUMBER
TM 9-1375-213-12-3/T0 11A20-15-1

PUBLICATION DATE
5 July 1994

PUBLICATION TITLE Op and Unit Maint
Manual for Firing Device, Demolition M122

BE EXACT PIN-POINT WHERE IT IS

PAGE NO	PARA-GRAPH	FIGURE NO	TABLE NO

IN THIS SPACE TELL WHAT IS WRONG AND WHAT SHOULD BE DONE ABOUT IT:

PRINTED NAME GRADE OR TITLE AND TELEPHONE NUMBER

SIGN HERE

TEAR ALONG PERFORATED LINE

FILL IN YOUR
UNIT'S ADDRESS

FOLD BACK

DEPARTMENT OF THE ARMY

POSTAGE AND FEES PAID
DEPARTMENT OF THE ARMY
DOD 314



OFFICIAL BUSINESS
PENALTY FOR PRIVATE USE \$300

COMMANDER
US ARMY ARMAMENT RESEARCH, DEVELOPMENT AND
ENGINEERING CENTER
ATTN: SMCAR-LSB
PICATINNY ARSENAL, NJ 07806-5000

TEAR ALONG PERFORATED LINE

